



J. Environ. Nanotechnol.
Volume 2 (2013) 59-69 pp.
ISSN (Print) : 2279-0748
ISSN (Online) : 2319-5541
doi:10.13074/jent.2013.02.nciset311

Development of Solar Power Tree – An Innovation that Uses Up Very Less Land and Yet Generates much more Energy from the Sun Rays by SPV Method

S.N. Maity

Technology Innovation Centre, Central Mechanical Engineering Research Institute, Durgapur.

Abstract

Energy and pollution are the present burning questions. So, there is an impending demand of an alternative green power. Solar, as believed, is the only major alternative in comparison to other sources of available renewable energies. For absorbing the sun solid silicon-crystalline photo-voltaic (SPV) method is the best. SPV panels are laid on structures at tilt angle. SPV is a land consuming system. Scarcity of land is the greatest crisis of the earth. **Solar Power Tree** is invented for installing PV-modules on a tall pole-like structure with branch-like panels and takes only 1% of land than conventional SPV layout.

Keywords : *Silicon-crystalline Photo-Voltaic (SPV), Solar Power Tree.*

1.INTRODUCTON

There is a big hue and cry over energy crisis from all over the world mainly for two reasons, firstly the natural resources are going to be exhausted very soon and the other is whether we should continue with the available natural resources of carbonaceous compound which is posing threat of greenhouse gas effect to human being every day. People are trying over different sources to find out non conventional energies, mainly some sort of renewable source of energy or the green energy like solar energy, wind energy, tidal power, hydro power etc. Power from sun, as it is thought today, is the only major alternative in comparison to other sources of renewable energies presently being tried to replace the conventional source of energies like coal, gas, oil etc.

Then how to tap the power of sun to be absorbed for our purpose?. There are many ways being devised time to time for absorbing the sun rays coming towards the surface of earth, but most

other methods of sun absorption like reflection, concentration, water heating etc. are the costly and complicated and efficiency is also less compared to PV modules.

One need to erect the PV panels under the sun so that the surface of panel gets the maximum sun of the day being laid at an angle. Today the general method is that hut like inclined structures are made over the land surface to hold the solar panels. Now for an example, the generation of 2MW power from PV module system requires the land of 10 Acres approx. for housing the panels only. But land is going to be the greatest crisis of the earth rather it is already a burning crisis in most of the countries. The cultivable land which is going to be the costliest commodity in the near future, if used for other than agriculture, it will be uncountable loss. Our many national projects are facing the severe problem of acquisition of land. Therefore if land area is used for capturing the solar power it would never be cost effective and viable for the human society. Therefore there is a need for devising a method and fabricating a suitable device so that the solar power can be absorbed without occupying much surface area,

S.N. Maity

E-mail : s_maity@cmeri.re.in

rather utilizing the minimum amount of land and the electricity must be economically viable...

Here comes the idea of a **Solar Power Tree** a new invention of installing PV modules on a tall pole like structure with leaf like branches surrounding it following a pattern of spiralling phyllotaxy as found in a natural tree. It would take only 1% of land area in comparison to general PV-housing layout as being practiced at present.

As example, it requires 0.4 Sq.M basements for 2.2 Kwh PV power, whereas by present general method of housing the PV arrays a land of 40 Sq.M is necessary for layout. It has so many other advantages to be discussed in this paper.

2. NEED FOR NEW INVENTION

Therefore there is a need for devising a



Fig. 1 & 2 : Conventional SPV Solar Plants, India

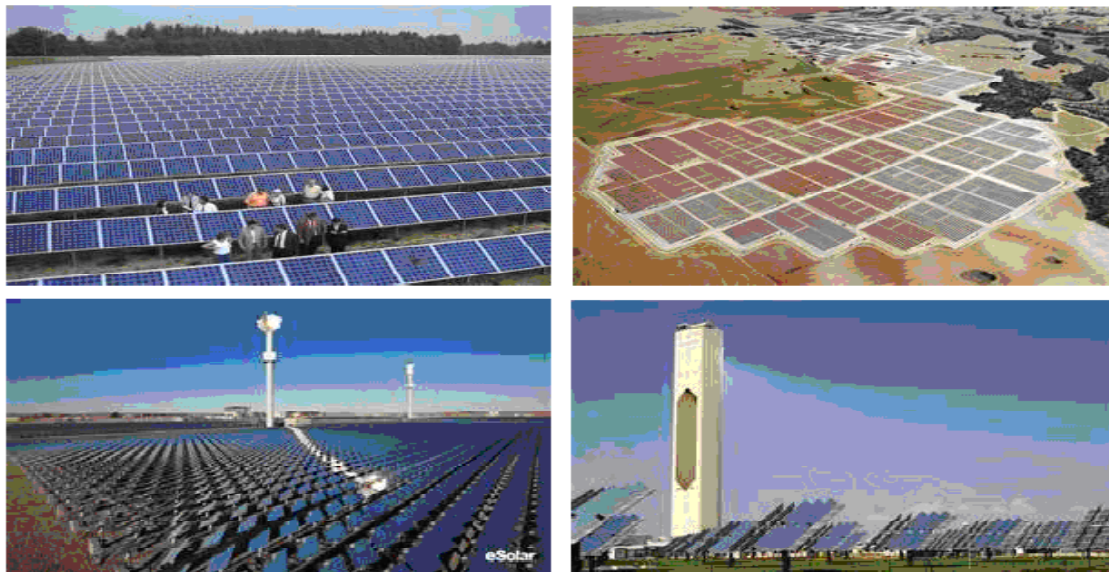

Fig. 3,4,5 & 6 Conventional Solar Plants (other countries)

method and fabricating a suitable device so that the solar power can be absorbed without occupying much surface area or land which is going to be the costliest commodity in the near future. Rather, the device and method should be such that it would be utilizing the minimum land for maximum solar power absorption by creating maximum solar surface and it was only possible by devising a holding system of PV modules with a vertical pole standing on the ground and holding the PV panels at a height.

Here comes the idea of a device of installing a tall metallic pole of 50 to 70 feet height founded on a basement of (2 X 2) Sq. feet area, which will hold all the required panels on its body like a tree (Fig-3). The surface land therefore is used only a maximum of 4 to 5 Square feet. Of course, it needs some base foundation for holding the taller pole but most of the foundation work will be below the ground surface.



Fig.7: Prototype of Solar Power Tree Capacity 2 KWh (Area 3 Sq. Ft)

Uniqueness and Advantages of Solar Power Tree:

The uniqueness of this single pole/solar power tree system is that the solar PV modules will be fixed throughout the tall pole following a pattern of spiralling phyllotaxy with due adjustment of load distribution over the pillar for its balancing. At the same the pattern is so maintained that the top panels wouldn't obstruct the bottom ones and each panel of the tree would get the maximum sun in a day time.

The other uniqueness is that all the Solar Panels will be hanging through their connecting stem-system attached with the main trunk (Pole) and may be made flexible in all direction so that they can best avoid the wind pressure due to heavy storm affecting over the main pole / trunk. The leaves (panels) would preferably be spring loaded and the Joints of stems would be flexible. The panels will be naturally facing towards the sun at an angle as required so that they can fix up maximum solar energy in a day time.

The advantages of this system is that it takes about 1% of land area in comparison to general PV housing layout, as example it requires 0.5 Sq M basement for 2.2 KWH PV power (Fig. 8) whereas for the same solar power by present general method of housing the PV arrays, a land of 50 Sq M is necessary for layout (Fig. 7).

The other advantage is that this system does not require the acquired big landed property at a single place, rather for this type of solar power generation the Road sides, the islands in between wide roads / highways, the boundary walls of paddy lands, the crossings of boundary walls etc. can be used.

Another advantage is that even if the divider walls of paddy land are used for solar power tree plantation, the shadow being created by the panels would not touch the land in most of the cases (as the Solar Power Trees would be very tall) and even if it touches, it won't cover the surrounding

field by its penumbra so that growth of plants would be restricted.

The unique advantage is that because of pattern of laying of panels following phylotaxy of natural trees and using the small size panels, the shadows coming from the panels of upper level do not interfere with the lower panels in most of the daytime. If sometimes they obstruct the lower ones that cover only very small percentage of panel area and for a little while only.

The dust deposition on the panels is a big problem for such type of solar power generation. Generally, as the panels of SPT are placed at higher height they are less subject to dust deposition. Again as the SPT structure is like a pagoda tree and an arrangement of water spraying from the top of the tree could make the panels clean if it works for a few minutes in the morning every day.

There is a big advantage in laying of panels inherited in this device of SPT that all the

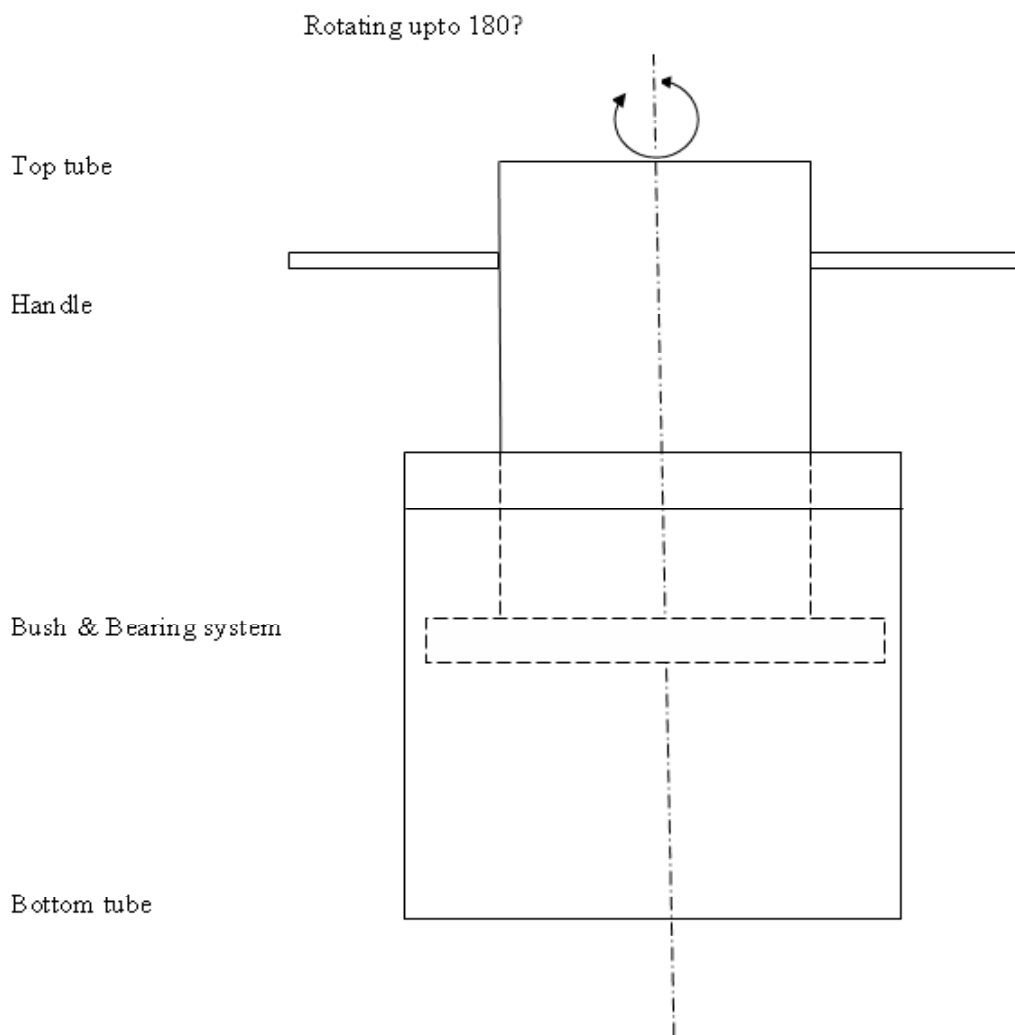

Fig. 8: Swivelling System of Solar Power Tree

panels can be laid in East – West direction, unlike the general fixed hut like structure where they are laid in South – North direction in general. An easy method can be devised with this SPT so that all the panels can be tilted around an angle of 45° as to get the maximum sun for whole the day. Instead of sophisticated electro-automated device, a simple mechanical device of pulling a rope can tilt all the panels from East – West to West – East direction to get the maximum sun path in a day quite economically.



Fig. 9a: Conventional Layout For 2 KWh (Area 350 Sq.ft)



Fig. 9b: Solar Power Tree At Night

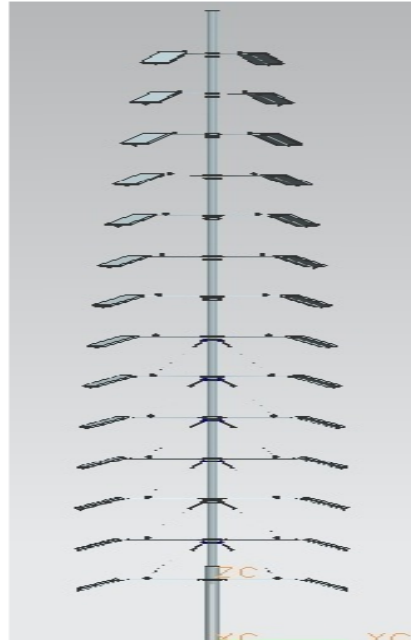

Fig. 10: Proposed SPV Solar Power Tree for 5 KWh

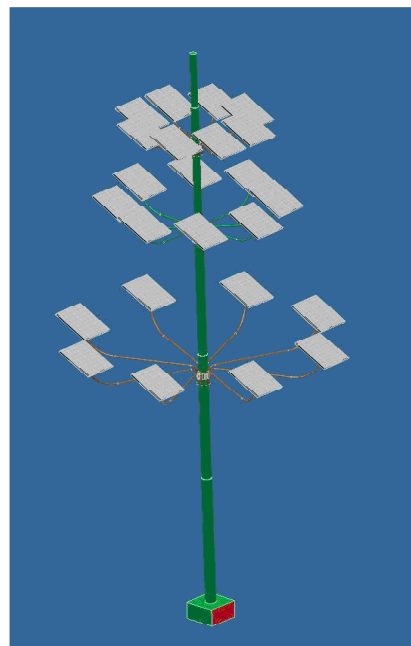

Fig. 11: Solar Power Tree - A Tall Single Trunk with Multi Stage Branches

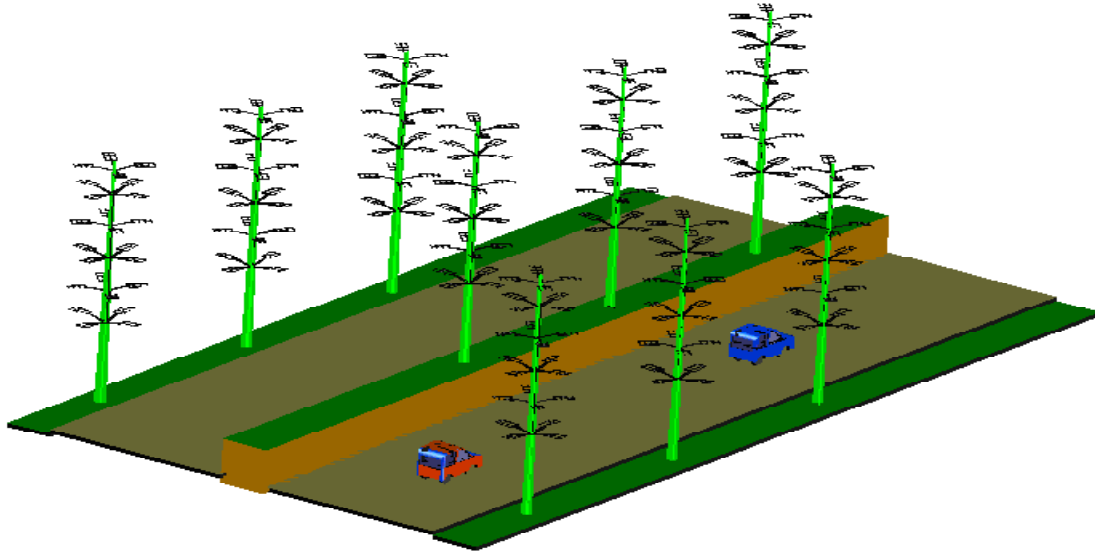

Fig. 12: Proposed Plantation of Solar Power Trees on Highway Sides

Example

Detailed Technical Specification

(Fabrication, Installation and Commissioning of Solar Power Tree)

This is a collection of 26 Nos. Solar PV Panels, which is mounted on a single tall pole with the help of suitable supporting arrangement. Total power generation is 1000Wh at peak hour on a clear sunny day.

- The arrangement maintains a Phyllotaxy pattern
- The electricity so produced being stored in a battery bank of suitable capacity
- The battery bank being protected from overcharging by Auto Cut-off
- The Battery bank is also attached with alternative charging system from 230V AC power
- A multiple lighting arrangement is provided for spending the accumulated solar energy
- Power supply to the lighting arrangement from battery bank with suitable timer/ manual switch.

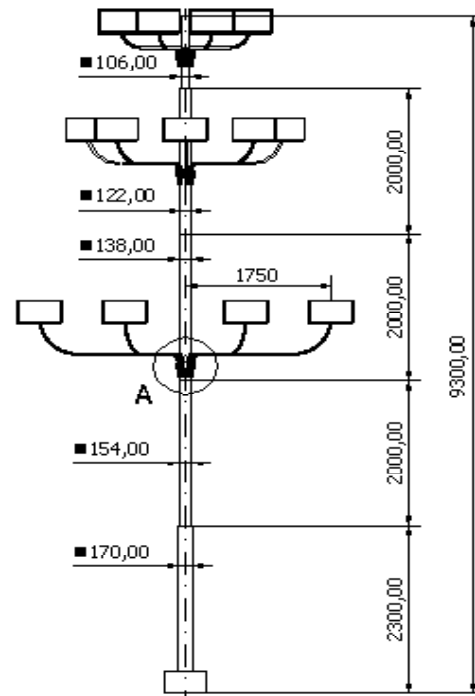

Fig.13: Schematic diagramme of general arrangement of PV Plant

2.1 Mechanical System

The drawing (fig.13) shows the General arrangement of the PV Panels, Panel Supports and the Pole. Altogether 26 Nos. of panels are arranged in a Phyllotaxy pattern. The Dimensions are tentative and may be deviated if required according to height of the pole.

Electrical system

After erection the whole assembly is to be painted to prevent from corrosion.

The whole assembly is to be anchored and grouted firmly at the site of erection.

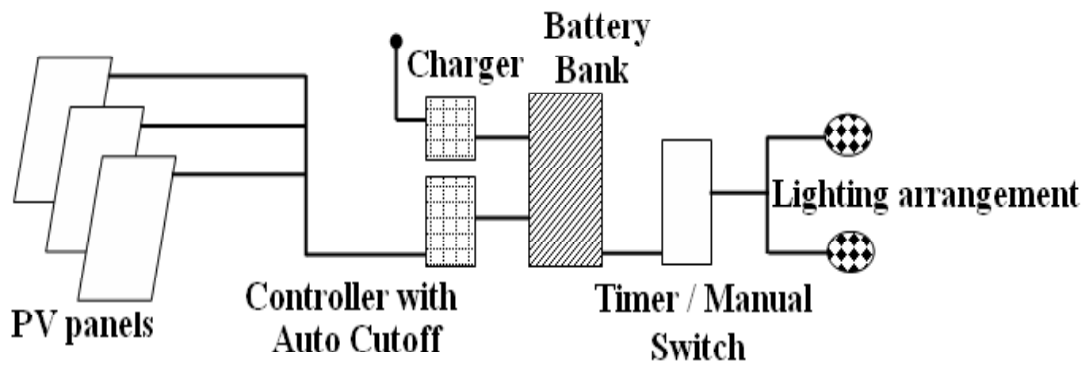

Fig. 14: Schematic Diagram of Electrical system

Civil Works

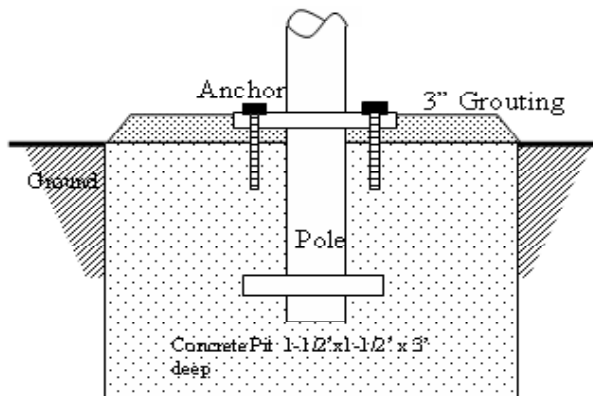

Fig. 15: Foundation of Pole

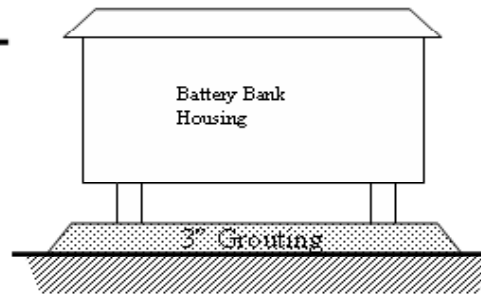

Fig. 16: Foundation of Battery Bank

Sl.	Detailed Description	Qty.
1	Pole with supporting arrangements (Fig. 13)	1 No.
2	Solar PV Panel	26 Nos.
3.	Controller and charging system (Fig. 12)	1 Set
4.	Additional charging system from 230V AC electric power line	1 No.
5.	Battery Bank of suitable capacity	1 Set
6.	Weather Proof metallic Battery Housing with grouting at site	1 No.
7.	Cut off system for excess power capture	1 No.
8.	High Efficiency LED light module with Mounting and Glass covering	2 Nos.
9.	Timer/Manual Switching system for lighting	1 No.
10	Concealed weather proof Cable Routing	1 Set
11.	Erection and associated Civil Work including Anchor, Pit and Grouting	1 Set
12.	Anti Corrosion Painting of the Total Assembly	1 Set

Data Collection : The variation and comparison of controller current between standard 40W panels fixed with an inclined hut like structure on the ground and similar type panels attached with the solar power tree under the invention at a height are represented in Table 1. and their respective plots are shown in Fig. 17, 18 & 19.

Table 1. SOLAR DATA COLLECTION

Date:	25.03.10		26.03.10		27.03.10	
Panel:	Standard layout	Solar Power Tree	Standard layout	Solar Power Tree	Standard layout	Solar Power Tree
Time	Ampere	Ampere	Ampere	Ampere	Ampere	Ampere
11:30 AM	4.96	4.4	4	4.70	3.88	4.16
11:45 AM	4.26	4.14	3.92	4.47	2.76	4.31
12:00 PM	2.24	3.78	3.92	4.59	2.72	4.12
12:15 PM	2.08	3.5	3.12	3.71	2.8	4.22
12:30 PM	1.84	2.1	3.76	3.57	2.56	3.58
12:45 PM	3.32	3.98	3.76	4.70	2.16	4.45
1:00 PM	3.20	3.3	3.68	3.96	2	3.43
1:15 PM	3.20	3.42	3.92	4.79	1.04	2.92
1:30 PM	2.32	2.94	3.72	3.06	0.8	1.68
2:15 PM	2.96	3.50	3.64	4.16	3.56	3.67
2:30 PM	3.24	4.25	3.6	4.48	3.88	5.20
2:45 PM	3.64	4.36	3.6	4.10	2.4	4.40
3:00 PM	1.88	1.86	3.24	4.15	2.04	4.69
3:15 PM	1.44	2.07	2.88	3.54	2.08	3.78
3:30 PM	1.80	2.56	3.12	2.82	2.56	3.33
3:45 PM	1.20	2.33	2.56	3.36	2.56	3.32
4:00 PM	1.32	2.35	2.48	2.77	2.44	2.94
4:15 PM	1.12	2.27	2.64	3.16	2.42	2.80
4:30 PM	0.68	1.89	1.12	2.32	2.4	2.07
4:45 PM	0.54	1.65	0.8	1.65	2.08	2.33
5:00 PM	0.24	1.05	0.25	1.16	1.22	2.28
5:15 PM	0.20	1.00	0.12	1.04	0.88	2.08
5:30 PM	0.10	0.89	0.11	0.98	0.20	1.40
5:45 PM	0.11	0.88	0.09	0.10	0.22	1.50

The graphical plot for the above data set is shown in Fig. 17, 18 & 19.

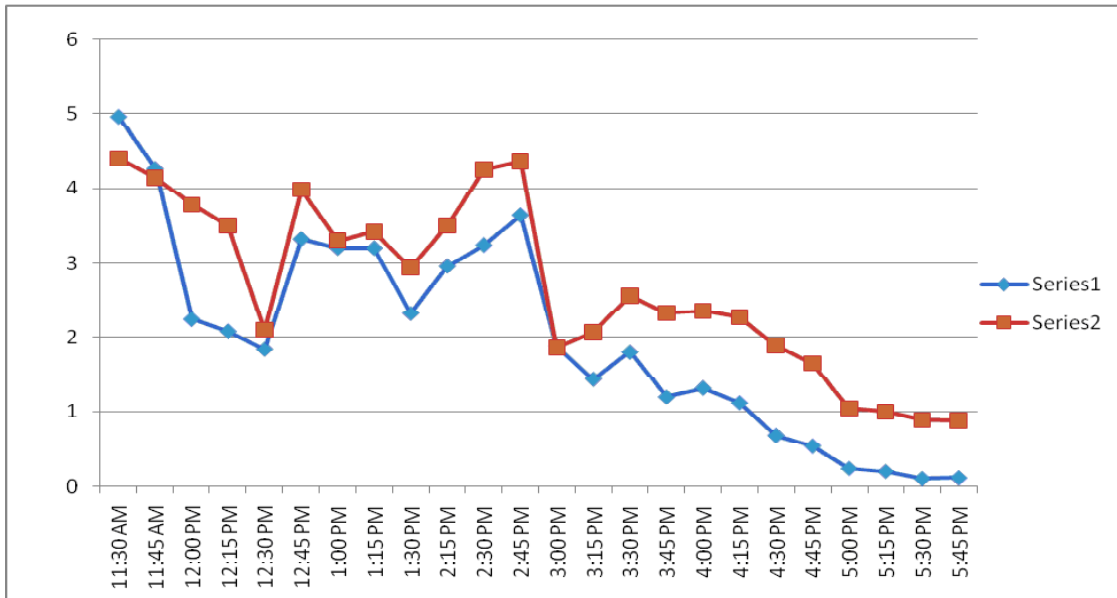

Fig. 17: Graphical Presentation: Comparison of output current between a panel of conventional low height structure (Series1) and a panel of Solar Power Tree (Series2) at height on 25/03/2010

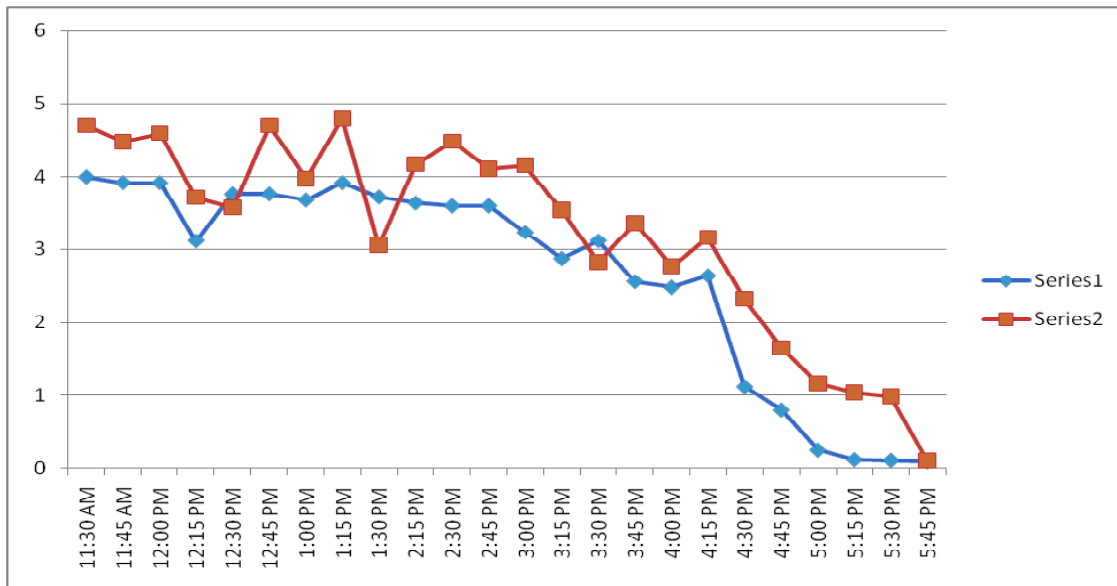

Fig. 18: Graphical Presentation: Comparison of output current between a panel of Conventional low height structure (Series1) and by a panel of Solar Power Tree at height (Series2) on 26/03/2010

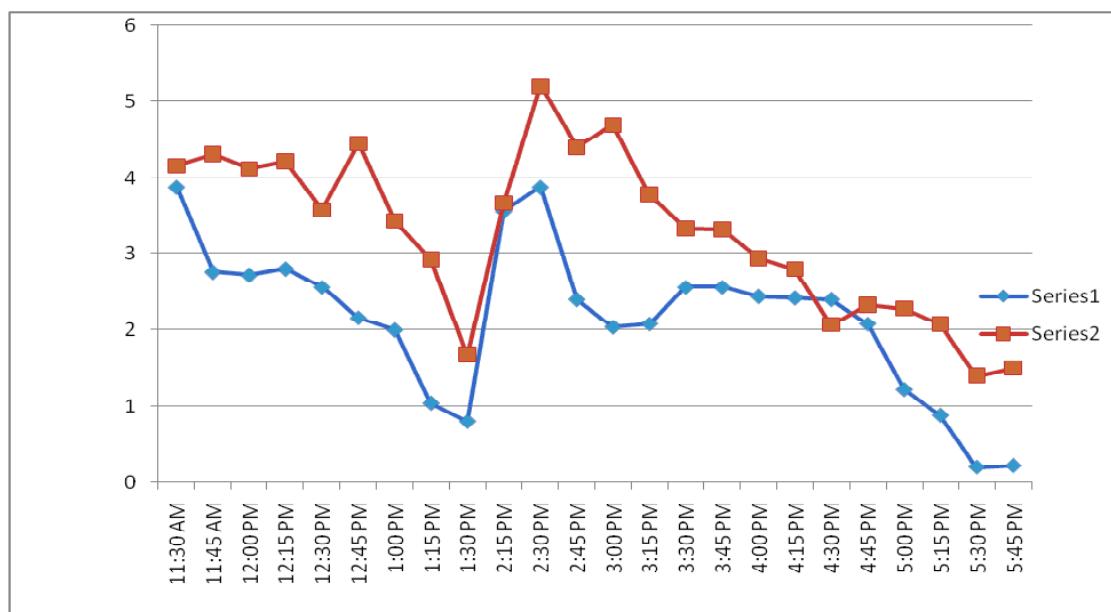

Fig. 19: Graphical Presentation: Comparison of output current by a panel on ground (Series1) and by a panel of Solar Power Tree at height (Series2) on 27/03/2010

3. CONCLUSION:

The solar power trees can be planted without any acquisition of vast land exclusively for this purpose in a particular place. They can be installed on the road sides as they consume around 4 Sq. Feet of area for a single tree. The village roads and the big boundary walls of paddy lands can provide sufficient space for planting solar power trees that can supply enough power for electrification of villages and irrigation activities. The state and national highways are big sources for Solar Power Tree (SPT) plantations. Two sides of single road high ways and the three sides of double road highways including island in between can be utilised for solar power trees (Fig. 13). A simple calculation shows that if the National Highway is used for plantation of solar power trees from Kolkata to Asansol which is around 300 kms in length it would be possible to produce 110 MW by installing solar power trees of 2KW capacity through the road sides at a certain interval (say 15 meter between two trees). This would actually require 660 Acres of land for the same power

generation at a single place by the existing method of laying out solar panels in a conventional way i.e. over the roofs of low height fixed structures. Hopefully if this new method of SPT plantation is adopted widely it would be possible to produce sufficient energy and to satisfy the demand of power for the world keeping the best ecological balance and preserving the nature as it is.

REFERENCES

1. Markvart, T. Photovoltaic Solar Energy Conversion. Proceedings of the Energy for Europe. 7th - 14th July. Strabourg. 2002.
2. P.Baruch. A two-level system as a model for photovoltaic solar cell. J. Appl. Phys. Vol 57. 1347. 1985.
3. L.L.Bucciarielli. The effect of day -to-day correlation in solar radiation on the probability of loss of powr in a stand - along photovoltaic energy systems. Solar energy. Vol 36. 11. 1986