



## Surface Acoustic Wave Devices and Sensors - A Short Review On Design and Modelling by Impulse Response

T. Venkatesan, Haresh M. Pandya\*

Department of Physics, Chikkanna Government Arts College, Tiruppur, TN, India.

Received : 07.07.2013 Revised : 16.08.2013 Accepted : 21.09.2013

### Abstract

A Surface Acoustic Wave (SAW) is a wave propagating along the surface of an elastic substrate with an amplitude that typically decays exponentially with depth into the substrate. To generate SAWs, an Interdigital Transducer (IDT) is used which can also act as a source or receiver of SAW. The present paper attempts to review the latest research work done in the last twenty years in design and computational modelling of such devices. Of the many computational models available, the Impulse Response model is selected, adopted and MATLAB is employed as a modelling tool for the simulation of the SAW device. Modelling results of a SAW delay line device functioning at a center frequency of 400 MHz with 25 finger pairs are studied and presented.

**Keywords:** Delay Line; Impulse Response; Modelling; SAW.

### 1. INTRODUCTION

Surface acoustic wave (SAW) devices based on piezoelectric materials have been in commercial use for over 60 years (Drafts, 2001). They are used in a wide variety of applications such as delay lines, oscillators, resonators, sensors, actuators, acoustic microscopy as well as in mobile phones. This industry consumes annually approximately three billion acoustic wave filters for frequency control. The filters are typically based on SAW and Bulk Acoustic Wave (BAW) resonator technology. Commonly used piezoelectric materials in SAW devices are single crystalline substrates of ST-X Quartz ( $\text{SiO}_2$ ), Lithium Tantalate ( $\text{LiTaO}_3$ ) and Lithium Niobate ( $\text{LiNbO}_3$ ) (Haresh M. Pandya *et al.* 2013).

A SAW Delay Line is one in which SAW travels along the surface of a piezoelectric substrate

and produce a time delay between the two Interdigital Transducers (IDTs) as shown in Fig.1. In 1965, White and Voltmer put forward the concept of Interdigital Transducer (IDT) as a source or receiver of surface waves. IDTs are placed on the surface of a piezoelectric substrate to generate and receive SAW. The travel length between receiver and transmitter IDT is called as Delay Time. A variation of the SAW travel length between the IDTs can be manipulated to get delays of different magnitude typically in the range of 1-50  $\mu\text{sec}$  (Campbell 1988). The area between the generator and receiver IDT is very sensitive to surface perturbation like mass loading and this area is generally coated with a chemically selective layer for adsorption of species in a SAW sensors. SAW sensors have been widely used for gaseous, chemical and biological species detection. With the advent of nanotechnology, and different modelling technique for the same (Haresh M. Pandya 2012), efforts have been made to increase the sensitivity of SAW sensors by integrating nanostructures on the active surface of the sensors (Penza *et al.* 2004, 2005;

---

\*Haresh M. Pandya Tel. : +919894336750  
E-mail : haresh.pandya@rediffmail.com



Varghese *et al.* 2003; Tomchenko, 2005; Haresh M. Pandya *et al.* 2010, 2011). Operating frequencies of SAW device as delay lines from 10MHz to 11GHz have been reported (Yamanouchi *et al.* 1988).

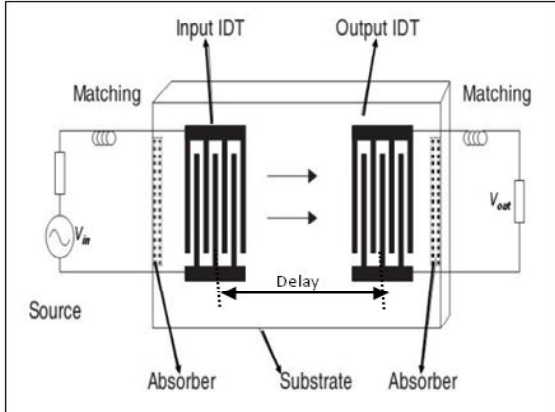

**Fig. 1 : Surface Acoustic Wave Device**

IDTs have a comb-like structure, where the distance between the fingers in the IDT determines the frequency of the waves propagating over the substrate. The study of these waves is useful in seismology and other areas, and recently there is much interest in modelling of these devices also (David Morgan, 2007; Rao *et al.* 2006; Mohammadi *et al.* 2007, 2009; Nomura *et al.* 1998).

## 2. SAW IMPULSE RESPONSE MODEL

The simplest way of understanding the physics and dynamics of SAW devices is through the Impulse Response Model (Hartmann *et al.* 1973). Generation and transduction of acoustic waves on a piezoelectric substrate has led to the development and concurrent usage of several different analytic approaches for its description (Ruppel *et al.* 1994; Smith *et al.* 1997; Feldmann *et al.* 1989; Tancrell *et al.* 1971).

The impulse response model was first presented by Hartmann *et al.* in 1973 as an improvement

over the delta function model and is derived from the impulse response of a non-dispersive transducer (Hartmann *et al.* 1973). The analysis and design of SAW transducers by an impulse response description has been discussed by several authors (Malocha, 1996; White, 1967; Tseng, 1968). Recently the impulse response model operating at 300MHz frequency using ST-X Quartz crystal substrate and 28.5 fingers pairs with split geometry electrodes has been successfully modelled and simulated by Haresh M. Pandya *et al.* (2013) and the interesting modelled results have been experimentally validated too.

Earlier, Carl *et al.* (1976), have explained that Transducer Effective Tap Amplitude Measurement (TETAM) method provides a means of accurately determining the true center frequency of bandpass filters. Minute changes of center frequency formerly masked by bandshape distortion are thus quantitatively measured. The effective strengths of SAW transducer elements are determined by measuring the discrete impulse response in a manner such that each sample is directly associated with a transducer element. The paper shows that TETAM is a valuable tool in the analysis of the impulse response of transducer structures and in the design of SAW signal processing elements.

Hashimoto *et al.* (1985) have described a frequency response of a SAW device based on Impulse Response model. The measurement is done without any numerical processing and calculation, and the result is immediately displayed on a spectrum analyzer. The method is mathematically based on Fourier analysis of impulse responses, which is done by a conventional spectrum analyzer (Langecker *et al.* 1980; Wagg, 1981; Kushibiki *et al.* 1982). This method permits separation of a specified response in the time domain from various responses primarily caused by different propagation modes or reflected waves in devices and same. (Hartmann *et al.* 1973) calculated transducer input admittance and filter frequency response from 10MHz to 1GHz. Also application of the impulse model to the straight forward design of VHF and higher frequency bandpass filters is studied and several examples of high

performance SAW device bandpass filters are presented (Tancrell *et al.* 1971; Smith *et al.* 1969).

Several authors have used the passband frequency response of SAW device filters. These include the use of computer-aided design techniques for obtaining finger geometry and apodization that were initially formulated for designing optimum finite impulse response (FIR) in linear phase digital filters (Monir *et al.* 1977; Tancrell *et al.* 1974; Engan, 1975; McClellan *et al.* 1973).

Impulse Response Method is a first order model. As a development of their model, two second order matrix methods namely- the conventional matrix approach and a modified matrix approach were introduced by Wilson and Atkinson extended to take into account internal finger reflections (Wilson *et al.* 2009; Hartmann *et al.* 1973) as displayed in Fig 2. (Hines *et al.* 1989) successfully utilized a double integral reduction technique on both isotropic and anisotropic substrates.

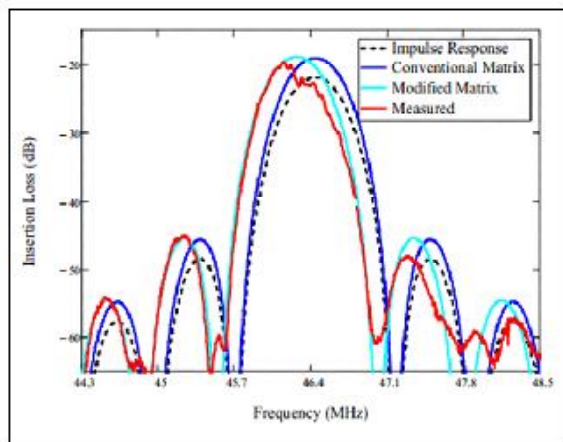

**Fig. 2 : Comparison of modelled results with data (Wilson *et al.*)**

Hirst *et al.* (2008) reported SAW device as a delay line bond-rupture biosensor. According to them, design constraints arise from both the manufacturing

process and intended application. The developed device is reusable. They have reported that reflector gratings or unidirectional transducers will decrease insertion loss and increase the acoustic energy at the sensitive area improving sensor operation.

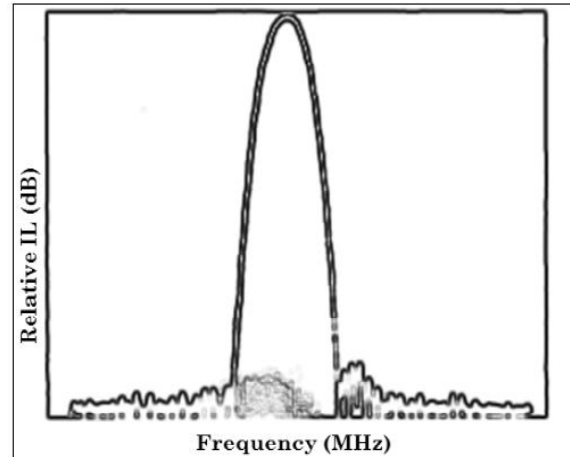

**Fig. 3 : Frequency response of SAW Filter**

Slobodnik *et al.* (1977) reported the process of design and realization of high performance SAW filters from initial specifications to final device operation. Effect of material properties, transducer weighting and computerized design are also treated and studied as shown in Fig.3 where in a clear peak is observed at the centre frequency.

Yatsuda *et al.* (1998) reported SAW device filters using slanted finger interdigital transducers (SFITs) which are suitable for mid-hand or wide-band applications.

Reindl *et al.* (2003) and Leonhard *et al.* (2004) reported a complete wireless sensor system by considering a SAW transponder and a local radar transceiver. Wei Luo *et al.* (2009) explained the theoretical analysis of wireless passive surface acoustic wave (SAW) impedance loaded sensors. They calculated amplitude variation of the impulse response in time domain and resonant characteristic with the

change of the loaded impedance. They reported that the return loss reaches the maximum value when the resonant frequency of the loaded circuits matches the center frequency of the short-circuited SAW transponder by based on the combined finite element method and boundary element method (FEM/BEM).

Junjing Zhou *et al.* (2008) reported the impulse response analysis of a SAW delay line based hydrogen gas sensors on Y-X cut LiNbO<sub>3</sub> substrate with a palladium film. The frequency response at a center frequency of about 100MHz was obtained. A three dimensional finite element model of SAW was employed for modelling of the same.

### 3. EQUATIONS OF IMPULSE RESPONSE MODEL

The Impulse Response method (Hartmann *et al.* 1973) was used as the baseline for modeling SAW device. This method is valid only for transducers where at least one of the two IDTs has a constant aperture or finger overlap (Campbell, 1998). This first order model includes both the mechanical and electrical behavior of SAW devices. It calculates the frequency response, the loss of the system, the admittance, and other related parameters. It assumes constant, equal spacing and finger widths. A simple Mason equivalent circuit model can be used to convey the basic elements of the Impulse Response Model as shown in Fig. 4.

According to this model, the total energy is found from the impulse response and is equated to the radiation conductance through the Hilbert transform. With a proper choice of a substratematerial-delay lines, filters, and other signal processing devices display a substantial improvement in performance (Haresh M. Pandya *et al.* 2011). The choice depends (Slobodnik *et al.* 1977) principally on velocity, coupling constant, temperature coefficient of delay (Campbell *et al.* 1968; Schulz *et al.* 1972) and propagation loss (Slobodnik *et al.* 1977; Budreau *et al.* 1979). Assuming a constant finger overlap or aperture and constant metallization ratio  $\eta(=a/b)$  between the IDT fingers and spaces, the

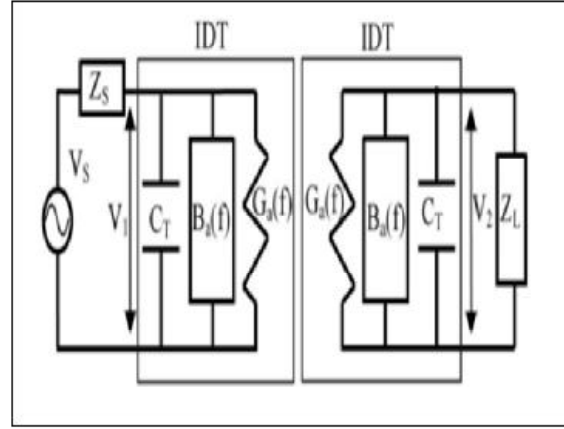

Fig. 4 : Mason equivalent circuit for Impulse response model (Gerard *et al.* 1969)

model provides a relatively easy method of calculating the frequency response, the insertion loss, and the related electrical parameters like IDT admittance  $Y$ , radiation conductance  $G(f)$ , acoustic susceptance  $B(f)$  and impedance  $Z(f)$ . Hartmann was able to establish that the time response  $h(t)$  of a SAW IDT transducer (Campbell, 1998) is given by

$$h(t) \propto 4\sqrt{K^2 C_s} f_0^{3/2}(t) \sin(2\pi f_0 t) \quad (1)$$

Where  $K^2$  is the electromechanical coupling coefficient,  $C_s$  is the electrode pair capacitance per unit length (pf/cm-pair) and  $f_0$  is the center frequency of operation.

Taking Fast Fourier Transform (FFT) of (1) we get,

$$H(f) = 20 \log \left[ \left[ 4K^2 C_s W f_0 N^2 \left( \frac{\sin X}{X} \right)^2 e^{-i \left( \frac{N+D}{f_0} \right)} \right] \right] \quad (2)$$

Where  $H(f)$  is frequency response of IDTs,  $W$  is aperture or finger overlap in the IDT,  $N_p = M = N$  are the number of IDT finger pairs of input and output IDT and  $D$  is the delay length in wavelengths between the IDTs. The variable defined as  $X$  in equation (2) is  $N_p \pi \left[ \left( \frac{f - f_0}{f_0} \right) \right]$

where  $f$  is the instantaneous frequency at any instant of time  $t$ .

**4. STRATEGY ADOPTED FOR MODELLING BY IMPULSE RESPONSE**

Several authors have successfully modelled SAW devices in India. (Haresh M. Pandya et al. 2013) has extensively studied computational modelling of SAW devices and has obtained interesting results. The present work is a continuum of the above referred works.

The various steps adapted by the authors for modelling of SAW devices are highlighted as follows:

- i. A Good efficient Substrate is selected for SAW propagation (properties of substrate are shown in **Table 1**). In present study ST-X Quartz substrate was selected.
- ii. The IDT is assumed to be made up of Aluminium (Al) material, because Al serves has an inert metal as well as good adhesive (Budreau et al.1971).

- iii. The uniform electrode IDT repeating structure is taken as  $\lambda$  and is related to inter electrode spacing ( $p$ ) by the relation  $\lambda = 2p$ . Single and Double electrode geometry patterns are shown in Fig. 5. In the present study, the number of finger pairs chosen was 25 at a center frequency of 400MHz.

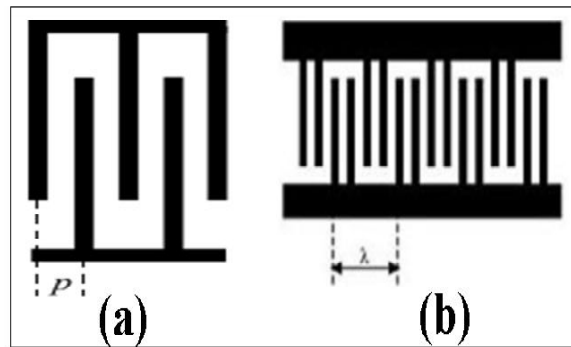

Fig. 5a: Single Electrode IDT ; 5b: Split Electrode IDT

Table 1. Common SAW Material Properties

SAW Material	$V_f$ (m/s)	$\Delta v/v$	Electromechanical Coupling Coefficient ( $K^2$ )%	Reference
Y-Z lithium Niobate ( $LiNbO_3$ )	3488	2.4%	4.8	Haresh M. Pandya, 2010;
128° Y-X lithium niobate ( $LiNbO_3$ )	3979	2.7%	5.4	Tsubouchi et al. 1985; Morgan, 1991;
ST-X quartz ( $SiO_2$ )	3159	0.06%	0.16	Hellwege et al. 1969

- iv. The input parameters for SAW device modelling according to impulse response model are taken as shown in **table 2**.
- v. Employing equations (1) and (2) of impulse response model, various output parameters are obtained (**Table 2**) as per the flowchart given below Fig 6.
- vi. For a SAW delay line device operating at 400MHz center frequency on ST-X quartz substrate and Al electrode finger in split electrode geometry (Fig 5b), a MATLAB algorithm was designed and modelled.
- vii. The algorithm provided simulated results of SAW delay line device namely
  - a) Frequency response of Impulse Response model for a center frequency at 400MHz (fig 7a).
  - b) Radiation conductance (fig 7b).
  - c) Acoustic susceptance (fig 7c).
  - d) Insertion loss (fig 7d).

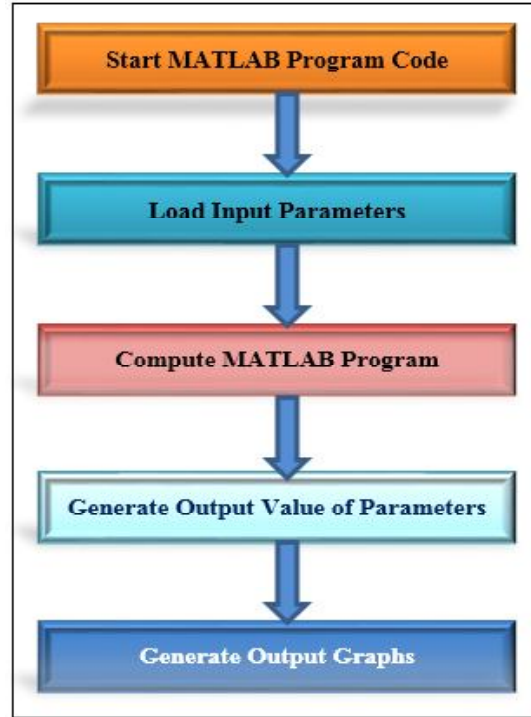
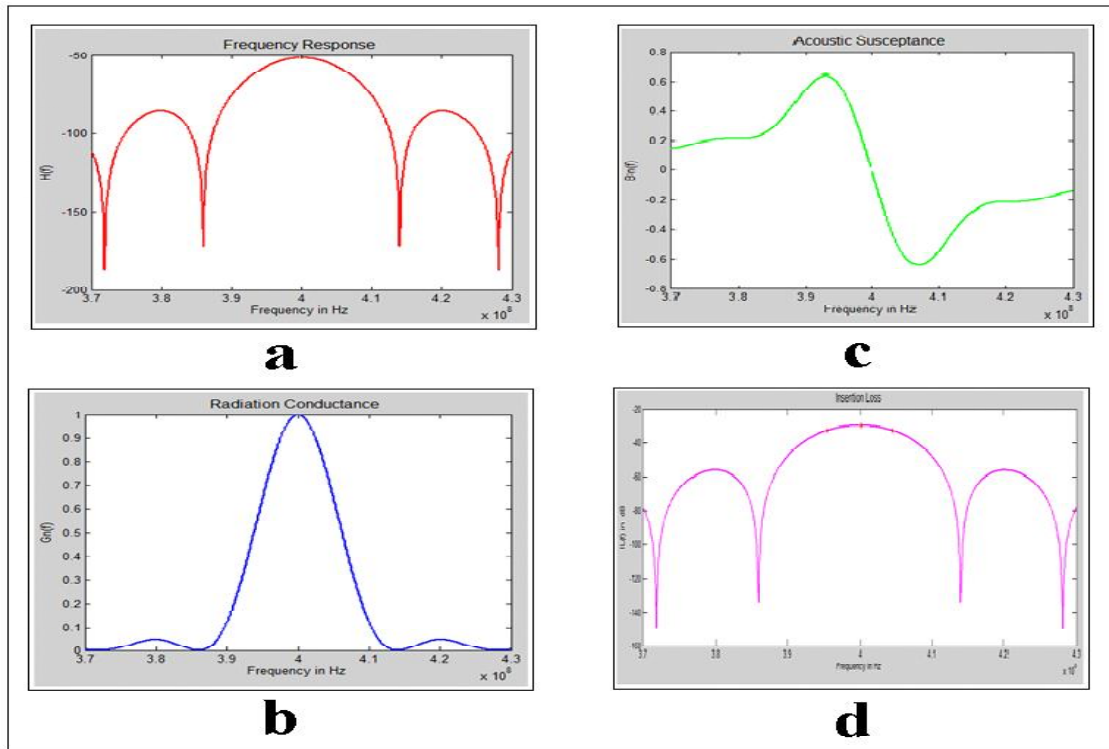

Fig. 6 : Flowchart of Modelling Strategy

Table 2. Input & Output parameters value of Impulse Response Model

S.No	Input Parameter	Output Parameter
1	Coupling coefficient ( $K^2$ ) 0.0016(Quartz)	Effective velocity of SAW (Vs) 3150m/s
2	Capacitance of finger pair/unit length (Cs) $0.55 \times 10^{-10}$ farad/m (Quartz)	Delay Time ( $\tau$ ) $2 \times 10^{-6}$ s
3	Centre frequency ( $f_0$ ) 400MHz	Insertion Loss(IL(f)) -29.94dB
4	IDT Geometry Split Geometry	3dB Bandwidth (BW) $8.9392 \times 10^6$ Hz



**Fig. 7a: Frequency response for 400MHz ; 7b: Radiation Conductance for 400 MHz ; 7c: Acoustic Susceptance for 400 MHz ; 7d: Insertion Loss for 400 MHz**

## 5. CONCLUSION

A comprehensive review of SAW devices and their dynamics with respect to the Impulse Response Model have been provided. The review spans over a period of research work done in this area in the last two decades. The computational study of these devices for design and modeling purposes is also presented. A 400 MHz SAW delay line device with 25 finger pairs is modelled and its impulse response and connected output parameters are graphically presented. It can be conclusively opined that SAW devices can be efficiently modelled using MATLAB as a computational tool for possible applications in SAW device design and response. In the future it is proposed to not only study SAW devices employing other modeling

approaches but to verify and validate the modelling results experimentally on a lab designed SAW device too.

## REFERENCE

- Andrew J., Slobodnik, Thomas L., Szabo and Kenneth R., Laker, Miniature Surface Acoustic wave Filter, *Proc. IEEE*, 67(1), 129–146(1979).<http://dx.doi.org/10.1109/PROC.1979.11209>
- Budreau, A.J., and Carr, P.H., Temperature Dependence of the Attenuation of Microwave Frequency Elastic Surface Waves in Quartz, *J. Appl. Phys.*, 18(6), 239–241 (1971).<http://dx.doi.org/10.1063/1.1653647>
- Campbell, C.K., Surface Acoustic Wave Devices for Mobile and Wireless Communications, Academic Press, San Diego, CA (1998).

- Campbell, J.J., and Jones, W.R., A Method for Estimating Optimal Crystal Cuts and Propagation Directions for Excitation of Piezoelectric Surface Waves, *IEEE T Son Ultrason*, 15(4), 209 - 217 (1968). <http://dx.doi.org/10.1109/T-SU.1968.29477>
- Carl M., Panasik and Bill J., Hunsinger, Precise Impulse Response Measurement of SAW filters, *IEEE T Son Ultrason*, 23(4), 239 - 248 (1976). <http://dx.doi.org/10.1109/T-SU.1976.30868>
- David Morgan, Surface Acoustic Wave Filters with Applications to Electronic Communications and Signal Processing, Elsevier, UK (2007)
- Drafts, B., Acoustic wave technology sensors, *IEEE T Microw Theory*, 49(4), 795-802 (2001). <http://dx.doi.org/10.1109/22.915466>
- Engan, H., Surface acoustic wave multielectrode transducers, *IEEE T Son Ultrason*, 22(6), 395-401 (1975). <http://dx.doi.org/10.1109/T-SU.1975.30825>
- Feldmann, M., and Henaff, J., Surface Acoustic Waves for Signal Processing, Artech House (1989).
- Gerard, H.M., Acoustic scattering parameters of the electrically loaded Interdigital surface wave transducer, *IEEE T Microw Theory*, 17(11), 1045-1046 (1969). <http://dx.doi.org/10.1109/TMTT.1969.1127095>
- Haresh M., Pandya, "Design and Modelling of Surface Acoustic Wave (SAW) Devices and Sensors", *Ph.D. Thesis*, Bharathiar University, Coimbatore, Jan-2010, pp. 8 (2010).
- Haresh M., Pandya, Modelling Scenario in Nanotechnology Today, *J. Environ. Nanotechnol.*, 1(1), 1-4, (2012). <http://dx.doi.org/10.13074/jent.2012.10.121020>
- Haresh M., Pandya, Kumar, P.R., Nimal A.T., Sharma, M.U., Equivalent Circuit MATLAB Modelling of a Surface Acoustic Wave (SAW) Delay Line for Sensor Applications, *Res J Chem Environ*, 90 (2011)
- Haresh M., Pandya, Rajesh, K.B., Nimal, A.T., Sharma, M.U., Impulse Modelled Response of a 300 MHz ST-Quartz SAW Device for Sensor Specific Applications, *J. Environ. Nanotechnol.*, 2, 15-21 (2013). <http://dx.doi.org/10.13074/jent.2013.02.nciset33>
- Haresh M., Pandya, Sharma, M.U., Nimal, A.T., Kaul, S.K., Dinesh, Simulation and Design of Surface Acoustic Wave Delay Line for Chemical Sensor Application, *International Journal of Applied Engineering Research*, 6(5), 903-906 (2011)
- Hartmann, C.S., Jr. Bell, D. T. Rosenfeld, R.C., Impulse Model Design of Acoustic Surface-Wave Filters, *IEEE T Microw Theory*, 21(4), 162-175 (1973). <http://dx.doi.org/10.1109/TMTT.1973.1127967>
- Hashimoto, Ken-Ya., Masatsune Yamaguchi, and Hiroshi Kogo, Frequency Response Measurement for SAW Devices Based on Fourier Analysis of Impulse Response, *IEEE T Son Ultrason*, 32(1), 76-77 (1985). <http://dx.doi.org/10.1109/T-SU.1985.31573>
- Hellwege, K. H. and Hellwege, A. M., ed., Group III: Crystal and solid state Physics, Landolt - Bornstein New series, 2, 40 - 97, Springer-Verlag, Berlin (1969).
- Hines, J. H., Malocha, D.C., and Brown, R.B., SAW Device Impulse Response Modeling using Broadband Diffraction Theory, *IEEE Ultrasonics Symposium*, 1, 25-29 (1989). <http://dx.doi.org/10.1109/ULTSYM.1989.66954>
- Hiroshi Yatsuda, and Kazuhiko Yamanouchi, Automatic Computer-Aided Design of Slanted Finger SAW Filters Using a Building-Block Method, *IEEE Ultrasonics Symposium*, 1, 239 - 241 (1998). <http://dx.doi.org/10.1109/ULTSYM.1998.762136>
- Hirst, E.R., Xu, W.L., Bronlund, J.E., and Yuan, Y.J., Surface Acoustic Wave Delay Line for Biosensor Application, *Mechatronics and Machine Vision in Practice*, 40 - 44 (2008). <http://dx.doi.org/10.1109/MMVIP.2008.4749504>
- Junjing Zhou, Chunmin Tao, Chenbo Yin, Analysis of Different Effect on the Response of SAW Hydrogen Gas Sensor, *IEEE on Nano/Micro Engineered and Molecular Systems*, 1168 - 1171 (2008). <http://dx.doi.org/10.1109/NEMS.2008.4484525>
- Kushibiki, J., Sannomiya, T., and Chubachi, N., A useful acoustic measurement system for pulse mode in VHF and UHF ranges, *IEEE T Son Ultrason*, 29(6), 338 - 342 (1982). <http://dx.doi.org/10.1109/T-SU.1982.31364>



- Langecker, K., and Veith, R., Automated time domain testing of SAW devices, *Proc. IEEE Ultrason. Symp.*, 396-399 (1980). [http://dx.doi.org/ 10.1109/ULTSYM.1980.197427](http://dx.doi.org/10.1109/ULTSYM.1980.197427)
- Leonhard M., Reindl, and Ismail M., Shrena, Wireless Measurement of Temperature Using Surface Acoustic Waves Sensors, *IEEE T Ultrason Ferr*, 51(11), 1457–1463 (2004). [http://dx.doi.org/ 10.1109/FREQ.2003.1275216](http://dx.doi.org/10.1109/FREQ.2003.1275216)
- Malocha, D.C., Surface acoustic wave design fundamentals, *Proc. International Microwave Conference*, Warsaw, Poland (1996).
- McClellan, J. H., Parks, T.W., and Rabiner, L.R., A computer program for designing optimum FIR linear phase digital filters, *IEEE Trans. Audio Electroacoust.*, 21(6), 506-526 (1973). [http://dx.doi.org/ 10.1109/TAU.1973.1162525](http://dx.doi.org/10.1109/TAU.1973.1162525)
- Mohammadi, S., Eftekhar, A.A., Khelif, A., Hunt, W.D., and Adibi, A., High-Q micromechanical resonators in a two-dimensional phononic crystal slab, *Appl. Phys. Lett.*, 94(5) (2009). [http://dx.doi.org/ 10.1063/1.3078284](http://dx.doi.org/10.1063/1.3078284)
- Mohammadi, S., Eftekhar, A.A., Khelif, A., Moubchir, H., Westafer, R., Hunt, W.D., and Adibi, A., Complete phononic bandgaps and bandgap maps in two-dimensional silicon phononic crystal plates, *Electron Lett*, 43(16), 898 - 899 (2007). [http://dx.doi.org/ 10.1049/el:20071159](http://dx.doi.org/10.1049/el:20071159)
- Monir H., El-Diwany and Campbell, C.K., Modification of Optimum Impulse Response Techniques for Application to SAW Filter Design, *IEEE T Son Ultrason*, 24(4), 277 - 279 (1977). [http://dx.doi.org/ 10.1109/T-SU.1977.30944](http://dx.doi.org/10.1109/T-SU.1977.30944)
- Morgan, D.P., *Surface Wave Devices for Signal Processing*, Elsevier, Amsterdam (1991).
- Nomura, T., Tekebayashi, M., Saitoh, A., Chemical sensor based on surface acoustic resonator using Langmuir-Blodgett film, *IEEE T Ultrason Ferr*, 45(5), 1261–1265 (1998). [http://dx.doi.org/ 10.1109/58.726452](http://dx.doi.org/10.1109/58.726452)
- Penza, M., Antolini, F., Antisari, M.V., Carbon nanotubes as SAW chemical sensor materials, *Sensor Actuat B-Chem*, 100, 47-59 (2004). [http://dx.doi.org/ 10.1016/j.snb.2003.12.019](http://dx.doi.org/10.1016/j.snb.2003.12.019)
- Penza, M., Tagliente, M.A., Aversa, P., Cassano, G., Organic vapor detection using carbon nanotube composites microacoustic sensors, *Chem Phys Lett*, 409, 349-354 (2005). [http://dx.doi.org/ 10.1016/j.cplett.2005.05.005](http://dx.doi.org/10.1016/j.cplett.2005.05.005)
- Rao, Y.L., Zhang, G., 3-D Finite Element Simulation of Nanostructure Enhanced SAW Sensors, *COMSOL Users Conference*, Boston, USA (2006)
- Reindl, L., Shrena, I., Kenshil, S., Peter, R., Wireless Measurement of Temperature Using Surface Acoustic Waves Sensors, *Proc. IEEE International Frequency Control* (2003). [http://dx.doi.org/ 10.1109/FREQ.2003.1275216](http://dx.doi.org/10.1109/FREQ.2003.1275216)
- Ruppel, C.C.W., Ruile, W., Scholl, G., Wagner, K.C., and Manner, O., Review of models for low-loss filter design and applications, presented at Proceedings of *IEEE Ultrasonic Symposium*, 1, 313-324 (1994). [http://dx.doi.org/ 10.1109/ULTSYM.1994.401602](http://dx.doi.org/10.1109/ULTSYM.1994.401602)
- Schulz, M.B., Matsinger, J.H., Rayleigh Wave Electromechanical Coupling Constant, *Appl. Phys. Lett.* 20, 367–369 (1972). [http://dx.doi.org/ 10.1063/1.1654190](http://dx.doi.org/10.1063/1.1654190)
- Slobodnik, A.J., Jr., Laker, K.R., Szabo, T.L., Kearns, W.J., and Roberts, G.A., “Low sidelobe SAW filters using overlap and with-drawal weighted transducers,” *IEEE in Ultrason. Symp.*, pp. 757- 762 (1977).
- Smith, P.M., Analysis techniques for surface acoustic wave devices, *IEEE MTT-S International Microwave and Optoelectronics Conference*, 1, 103 - 108 (1997). [http://dx.doi.org/ 10.1109/SBMOMO.1997.646834](http://dx.doi.org/10.1109/SBMOMO.1997.646834)
- Smith, W.R., Gerard, H.M., Collins, J.H., Reeder, T.M., and Shaw, H.J., Analysis of interdigital surface wave transducers by use of an equivalent circuit model, *IEEE T Microw Theory*, 17(11), 856–864 (1969). [http://dx.doi.org/ 10.1109/TMTT.1969.1127075](http://dx.doi.org/10.1109/TMTT.1969.1127075)
- Szabo, T.L., and Slobodnik, A.J., Jr., Diffraction compensation in periodic apodized acoustic surface wave filters, *IEEE T Son Ultrason*, 21(2), 114-119 (1974). [http://dx.doi.org/ 10.1109/T-SU.1974.29800](http://dx.doi.org/10.1109/T-SU.1974.29800)

- Tancrrell, R., Analytic design of surface wave bandpass filters, *IEEE T Son Ultrason*, 21(1), 12-22 (1974). <http://dx.doi.org/10.1109/T-SU.1974.29785>
- Tancrrell, R.H., and Holland, M.G., Acoustic surface wave filters, *Proceedings of the IEEE*, 59(3), 393-409 (1971). <http://dx.doi.org/10.1109/PROC.1971.8180>
- Tomchenko, A.A., Harmer, G.P., Marquis, B.T., Detection of chemical warfare agents using nanostructured metal oxide sensors, *Sensor Actuat B-Chem*, 108, 41-55 (2005). <http://dx.doi.org/10.1016/j.snb.2004.11.059>
- Tseng, C.C., Frequency response of an interdigital transducer for excitation of surface elastic waves, *IEEE T Electron Dev*, 15(8), 586-594 (1968). <http://dx.doi.org/10.1109/T-ED.1968.16406>
- Tsubouchi, K., and Mikoshiba, N., Zero-Temperature Coefficient SAW Devices on AlN Epitaxial Films, *IEEE T Son Ultrason*, 32(5), 634-643 (1985). <http://dx.doi.org/10.1109/T-SU.1985.31647>
- Varghese, O.K., Gong, D., Dreschel, W.R., Ong, K.G., Grimes, C.A., Ammonia detection using nanoporous alumina resistive and surface acoustic wave sensors, *Sensor Actuat B-Chem*, 94, 27-35 (2003). [http://dx.doi.org/10.1016/S0925-4005\(03\)00252-1](http://dx.doi.org/10.1016/S0925-4005(03)00252-1)
- Wagg, M.W., Bulk acoustic waves in solids, D-Phil thesis, Oxford, 113-114, (1981).
- Wei Luo, Qiuyun Fu, Jianling Wang, Yi Wang, and Dongxiang Zhou, Theoretical Analysis of Wireless Passive Impedance-Loaded SAW Sensors, *IEEE Sensors Journal*, 9(12), 1778 - 1783 (2009). <http://dx.doi.org/10.1109/JSEN.2009.2029812>
- White, R.M., Surface elastic-wave propagation and amplification, *IEEE T Electron Dev*, 14(4), 181-189 (1967). <http://dx.doi.org/10.1109/T-ED.1967.15926>
- White, R.M., and Voltmer, F.W., Direct piezoelectric coupling to surface elastic waves, *Appl. Phys. Lett.*, 7, 314,316 (1965). <http://dx.doi.org/10.1063/1.1754276>
- Wilson, W.C., Atkinson, G.M., A Comparison of Surface Acoustic Wave Modeling Methods, *Micro Devices to Wireless Systems*, 7, 150-159 (2009)
- Yamanouchi, K., Cho, Y., and Meguro, T., SHF-range surface acoustic wave filters with inter-digital transducers using electron-beam exposure, *Pro. IEEE Ultrason. symp.*, 1, 115 - 118 (1988). <http://dx.doi.org/10.1109/ULTSYM.1988.49352>