



Fuzzy Logic Controller-based Intelligent Irrigation System Using Solar Radiation Data

K. C. Jayasankar¹, G. Anandhakumar^{1*} and A. Kalaimurugan²

¹Department of Electrical and Electronics Engineering, Saveetha School of Engineering, SIMATS, Saveetha University, Chennai, TN, India

²Department of Electrical and Electronics Engineering, Agni College of Technology, Chennai, TN, India

Received: 29.04.2024 Accepted: 24.05.2024 Published: 30.06.2024

*anandhakumar@saveetha.com

ABSTRACT

Solar radiation is a critical factor influencing agricultural productivity and water resource management. Irrigation systems play a pivotal role in maintaining crop health and yield, and optimizing their operation requires accurate solar radiation data. This abstract explores the significance of solar radiation data in enhancing the efficiency of irrigation systems. Irrigating agricultural fields using an intelligent information system plays a crucial role. This study introduces an irrigation control system employing closed-loop control to use the available water resources efficiently. Continuous data collection from field sensors was done and transmitted to a central station in wireless mode. The data was then retrieved and processed in a computer-based or microcontroller-based solution model, enhancing system autonomy, reliability, and cost-effectiveness. Weather conditions are translated into fuzzy set values. The pump, water outlet valves, and sprinklers are set into motion according to control commands. This research simplifies the need for manual labor and reduces water wastage.

Keywords: Solar radiation data; Fuzzy logic controller; Irrigation system; Sensors.

1. INTRODUCTION

Solar radiation data-based irrigation systems, also known as solar-powered smart irrigation systems, leverage solar energy and real-time solar radiation data to optimize the irrigation process in agricultural and landscaping contexts. These systems integrate advanced technologies to enhance water efficiency, reduce operational costs, and promote sustainable agricultural practices. A soil profile can be divided into two parts: one that is saturated with water and another that is not fully saturated, called the unsaturated section. Soil moisture refers to the water content within the unsaturated zone, which is available for plants to utilize (Bwambale *et al.* 2022). Precipitation, entering the soil through infiltration, primarily feeds the unsaturated zone with moisture. The moisture is initially released through evaporation from exposed surfaces and transpiration from vegetation. The unsaturated zone's moisture content decreases as soil moisture travels vertically and progressively replenishes the water table (Ridolfi *et al.* 2003).

The equilibrium amidst turbulent motions within the atmosphere and the interchange of warmth, influenced by surface temperature and atmospheric steadiness proximal to the earth, is governed by the moisture content in the earth (Roberts *et al.* 2012; Settin *et al.* 2007; Khong *et al.* 2015). The survival of this division hinges upon variances in earth's moisture content that are not compulsory (Zhu and Lin, 2011).

This diagnostic formulation computes an approximation of soil moisture by contemplating the ratio of projected soil moisture depletion vis-à-vis the cumulative impact of antecedent rainfall incidences; it proves particularly expedient for agricultural and irrigation endeavors owing to its uncomplicated methodology for gauging soil moisture dynamics. Details regarding antecedent soil moisture levels are deemed superfluous (Pan *et al.* 2015) (Pan and Nieswiadomy, 2016).

Despite the advancements in computational technology, there has been a proliferation of methodologies for precise estimation of soil moisture, encompassing machine learning and remote sensing via platforms such as Google Earth Engine (Joshi *et al.* 2023; Mashala *et al.* 2023; Ahmad *et al.* 2022). Numerous machine learning methodologies rely on extensive datasets to attain accuracy. Moreover, the majority of global soil moisture monitoring satellites encounter limitations in solely gauging surface soil moisture (Scowen *et al.* 2021). Given the correlation between evapotranspiration, atmospheric temperature, and solar irradiation, the integration of additional environmental parameters may enhance the accuracy of estimating the coefficient for the loss function. The global consumption of water for various purposes, particularly irrigation, is increasing rapidly. In India, rainwater-based harvesting is the primary method for irrigating crops, except in a few regions. Natural water availability is limited on an annual basis; therefore, predicting water consumption is crucial

for meeting human needs (Atsalakis and Minoudaki, 2007). The central element of the entire irrigation system is the planning and building of an irrigation controller system. This system is valuable for farmers or gardeners to regulate the distribution of water and fertilizers to plants. As a result, farmers can achieve optimized outcomes by using minimal water and fertilizers during irrigation. Irrigation control systems can be generally divided into two primary categories: open-loop systems and closed-loop systems (Bwambale *et al.* 2022). Open-loop controllers adhere to a predetermined control strategy without taking input or feedback from the controlled system. They operate based on user-defined time settings for starting, stopping, pausing, and scheduling irrigation intervals. However, these controllers lack the ability to cross-check and measure

water quantities during irrigation, though they are cost-effective. Conversely, closed-loop controllers integrate pre-established control principles with input from the controlled system; they incorporate various parameters such as agricultural factors viz., plant type, soil type, growth stage, leaf coverage and environmental factors viz., temperature, humidity, solar radiation, soil moisture, to determine appropriate irrigation volumes. This controller system obtains feedback from diverse sensors to monitor real-time system conditions like soil moisture and solar radiation levels. By comparing sensor readings with preset parameters such as plant characteristics, soil properties, the controller makes informed decisions about regulating water and fertilizer distribution. The overall system architecture is illustrated in Fig. 1.

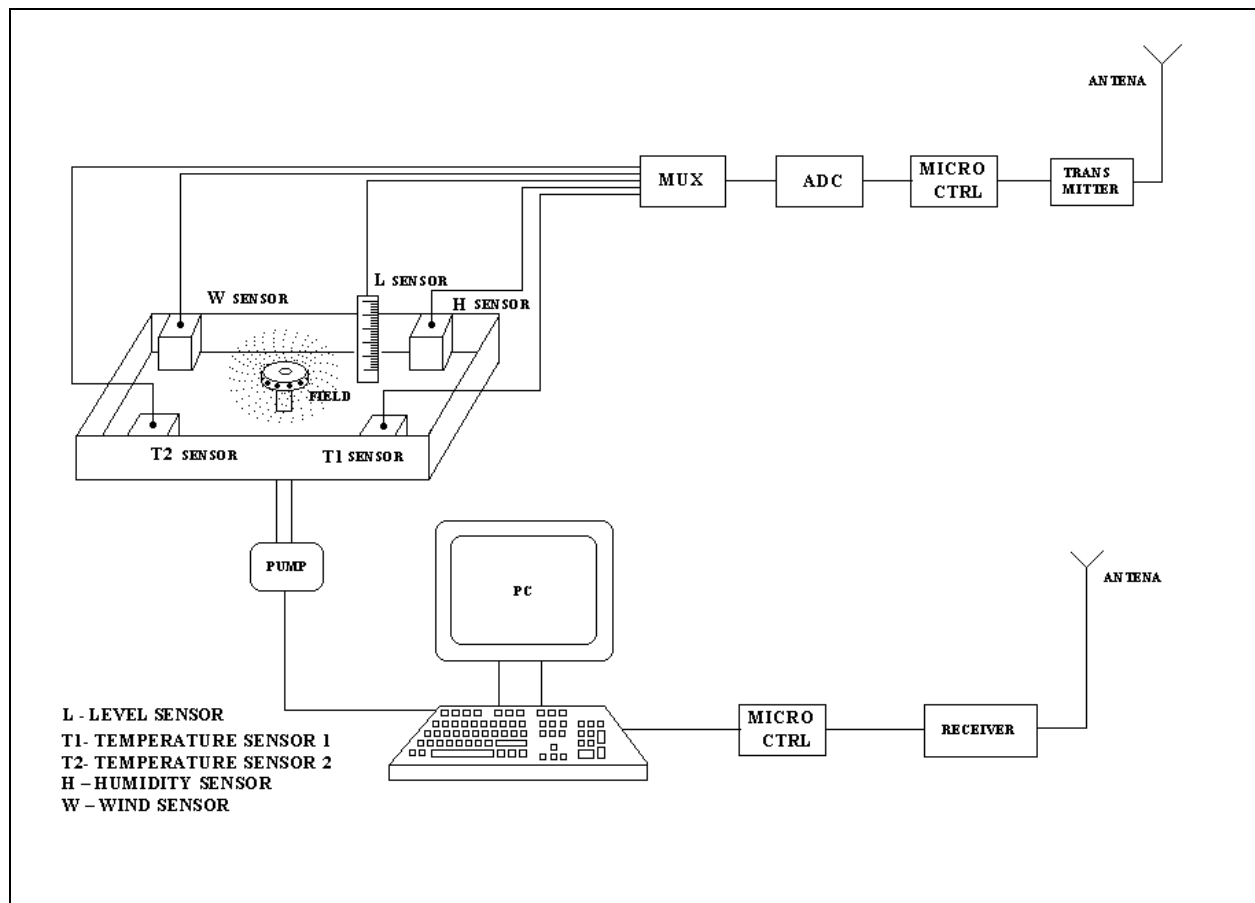

Fig. 1: Block Diagram of the Setup

2. METHODOLOGY

2.1 Development of Fuzzy Model

The three stages involved in using fuzzy logic are fuzzification, rule assessment, and defuzzification were depicted in Fig. 2. In the framework of the training, the Mamdani inference process was applied, employing standard fuzzy operations along with the centroid

defuzzification technique. One practical application source reliably yields many uncertain results in a fuzzy mechanism. Furthermore, the majority of fuzzy systems accommodate numerous real-world inputs, thereby employing multiple membership functions to assess each input. As anticipated, the justification step yields a greater number of fuzzy inputs than the actual real-world inputs. The creation of regulations was accomplished using MATLAB® in combination with the Fuzzy Logic

Tool Box resilient to a fundamental Mamdani system, as illustrated in Fig. 3. With the knowledge gathered from this data, the fuzzy inference system's structure and rules were created through data analysis and observation pertaining to plant stress. Fig. 4 illustrates the MATLAB

simulation procedure. To adjust the membership functions with respect to quantity, limits, and form, we utilized the interactive graphical features provided by the MATLAB Fuzzy Toolbox's Fuzzy Inference Editor (Al-Faraj *et al.* 2001).

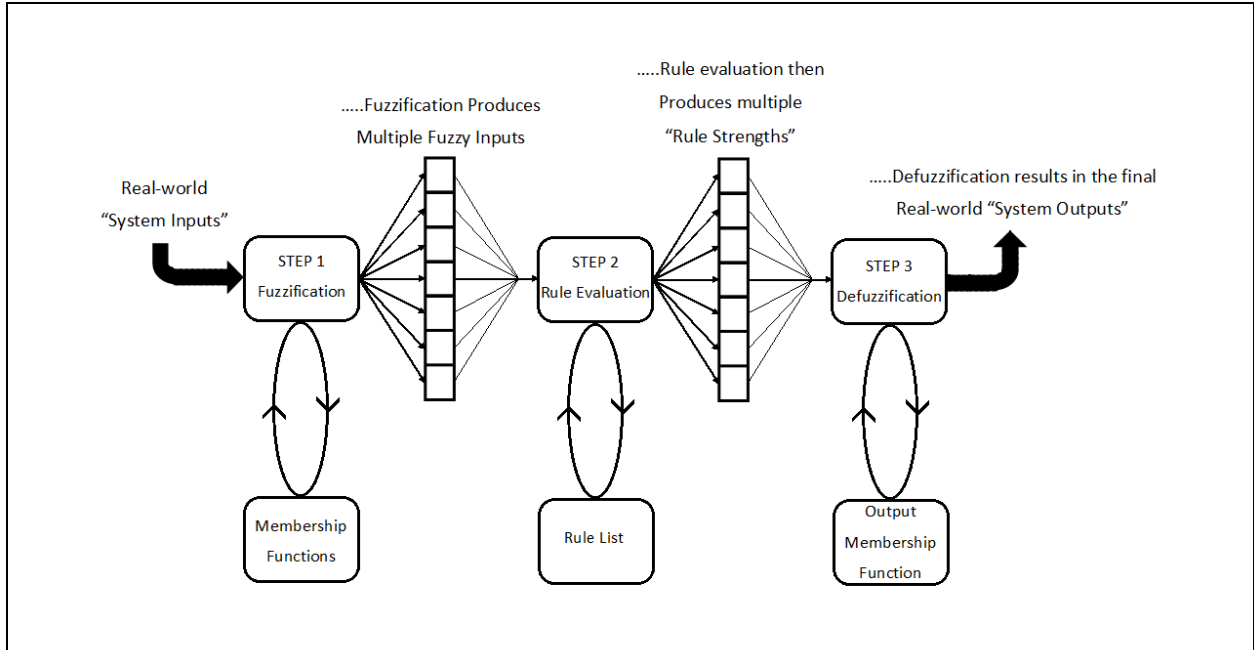

Fig. 2: Step-by-step process used in Fuzz Logic system

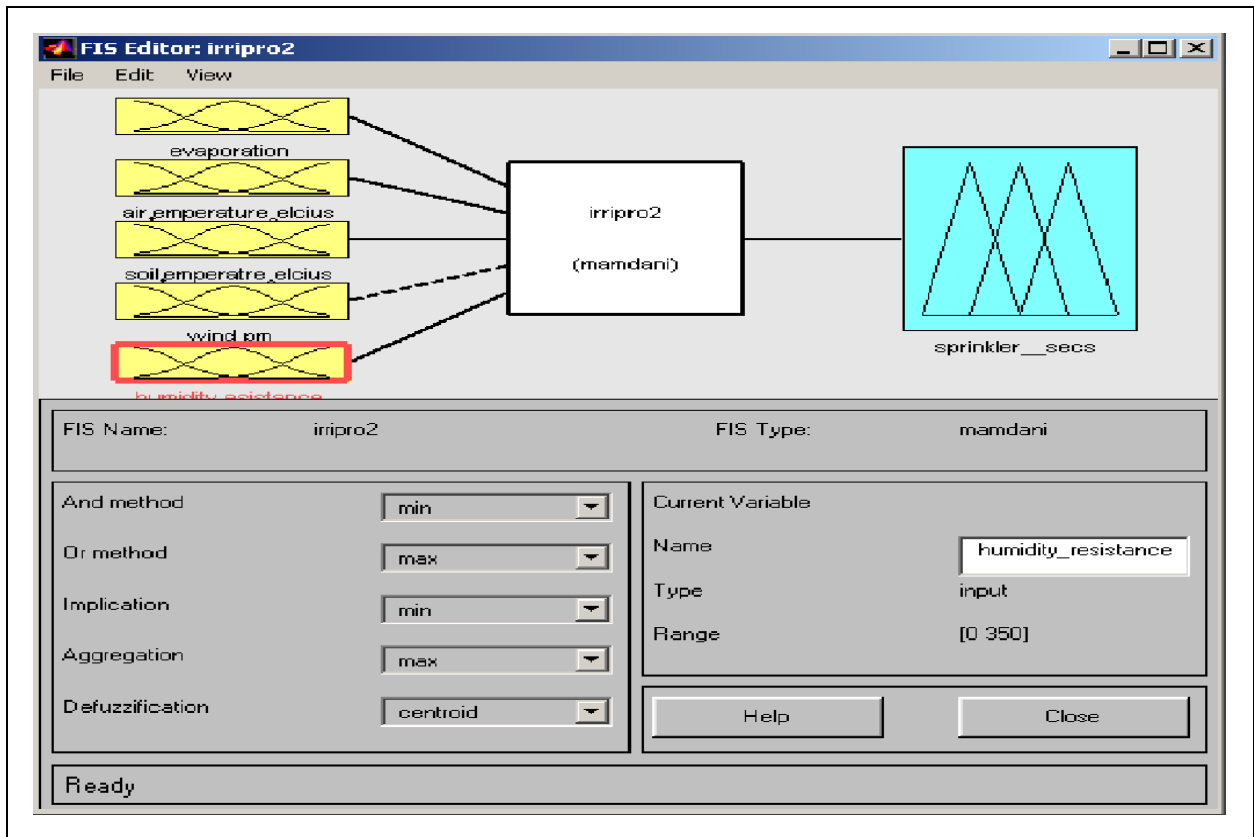

Fig. 3: Simple Mamdani system-based Fuzzy Logic Tool Box

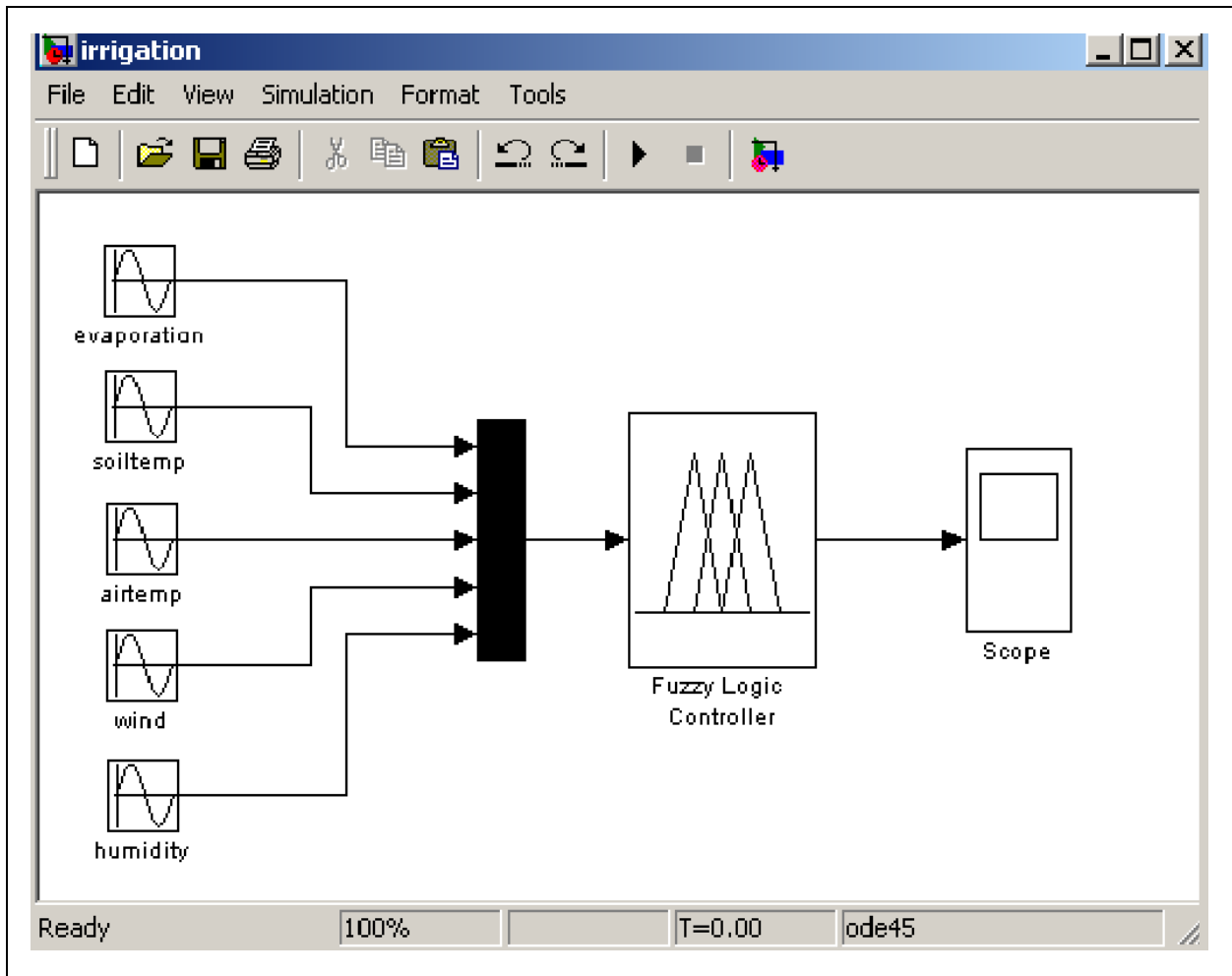

Fig. 4: Simulation process using MATLAB

2.2 Fuzzification

The technique of turning actual information into inputs that are fuzzier is known as "fuzzification.". This process involves assessing real-world inputs by utilizing a set of membership functions to link them with fuzzy inputs. On a graphical representation, the real-world inputs are displayed on the x-axis, while the corresponding fuzzy inputs are depicted on the y-axis, with values ranging from 0 to 1. Fuzzification is a technique applied to multiple parameters, as detailed below.

For example, when we examine the practical impact of temperature vs. membership function, as shown in Fig. 5, to assign specific numerical values like "cold," "normal," and "hot." To clarify, if the temperature input is 60 °C, the resulting fuzzy values would be: "cold" is 0.0, "normal" is 1.0, and "hot" is 0.0, as 60°C falls completely within the "normal" category. However, it's important to note that this consistency isn't guaranteed, because the outputs of various membership functions might have differing strengths. Consequently, three fuzzy inputs are produced from an individual practical

problems information, such as 38 °C: "cold" is 0.5, "normal" is 0.5, and "hot" is 0.0.

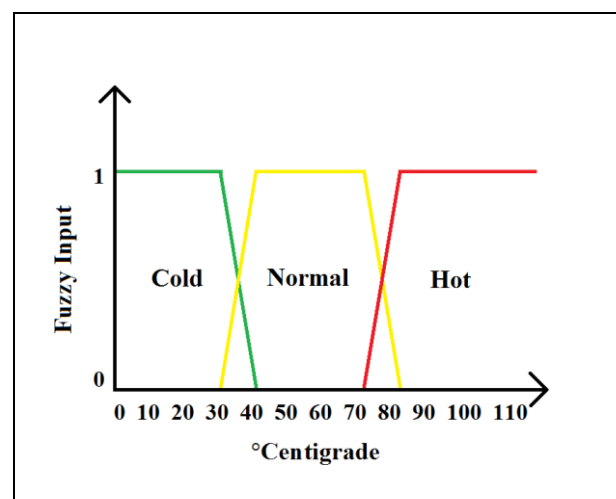

Fig. 5: Membership function for Temperature

Similarly, the actual soil moisture input behaves in a comparable manner, exhibiting a clear membership

function (as illustrated in Fig. 6). Evaluating this membership function follows a process analogous to that used for temperature. To illustrate, when a soil moisture input of 60% is used, the fuzzy values generated are 0.0 means dry, 1.0 means medium, and 0.0 means wet. These three classifications viz., dry, moist, and wet are used to categorize soil moisture statuses and associate them with various components.

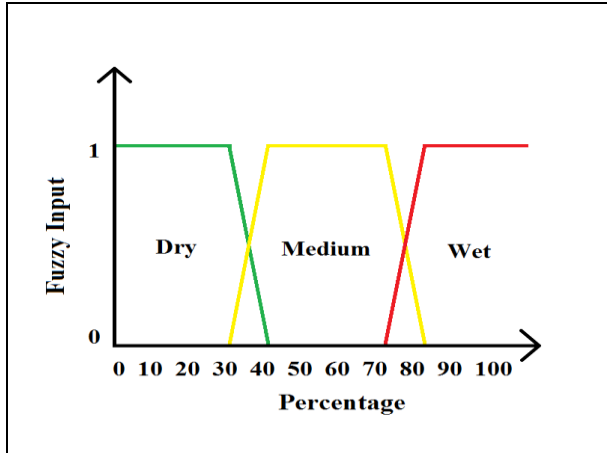

Fig. 6: Membership function for Moisture

2.3 Rule Evaluation

Here are six illustrative guidelines that define the functioning of the system:

- When the external temperature is categorized as "hot" and the detected soil moisture level is classified as "dry," activate the sprinkler system for an extended time span.
- If the outdoor temperature falls within the "normal" range and if the soil moisture reading shows "wet" conditions, activate the sprinkler system briefly.

- When the external temperature is categorized as "cold" and the detected soil moisture is "moderate," activate the sprinkler system briefly.
- If the evaluated soil moisture content is in the "medium" range and the outside temperature is classified as "hot," turn on the sprinkler system for a longer period of time.
- When the external temperature falls within the "normal" range, and the monitored soil moisture level indicates "dry" conditions, activate the sprinkler system for a prolonged duration.
- In instances where the external temperature is denoted as "cold," and the documented soil moisture level signifies "wet" conditions, commence a brief activation of the irrigation mechanism.

It has to be noted that while these six rules serve to illustrate the system, there could be additional rules for better controls.

2.4 Defuzzification

The approach employed for the process of defuzzification is denoted as the Central Gravity algorithm, frequently abbreviated as CoG (Centre of Gravity). The overarching expression for defuzzification is delineated as follows:

Real – world output

$$= \frac{(Fuzzy\ output\ weight\ i)(singleton\ position\ on\ x - axis\ i)}{(Fuzzy\ output\ weight\ i)}$$

The prevailing configuration dictates that the actual outcome is ascertained through the calculation of the ratio between the aggregate fuzzy output weight parameters' product and the specific positioning of each parameter relative to the cumulative fuzzy output weight of all the parameters.

$$= \frac{\left(\begin{matrix} Fuzzy \\ output \\ weight\ of \\ Short \end{matrix} \right) \left(\begin{matrix} singleton \\ position \\ of \\ Short \end{matrix} \right) + \left(\begin{matrix} Fuzzy \\ output \\ weight \\ of\ Medium \end{matrix} \right) \left(\begin{matrix} singleton \\ position \\ of \\ Medium \end{matrix} \right) + \left(\begin{matrix} Fuzzy \\ output \\ weight\ of \\ Long \end{matrix} \right) \left(\begin{matrix} singleton \\ position \\ of \\ Long \end{matrix} \right)}{\left(\begin{matrix} Fuzzy\ output\ weight \\ of\ Short \end{matrix} \right) + \left(\begin{matrix} Fuzzy\ output\ weight \\ of\ Medium \end{matrix} \right) + \left(\begin{matrix} Fuzzy\ output\ weight \\ of\ Long \end{matrix} \right)}$$

After the phases of rule assessment and fuzzification are complete, it results in the following fuzzy output values: Short is 0.3, Medium is 0.45, and Long is 0.7; then, the real-world output is determined as follows:

Real – world output

$$= \frac{(0.3)(0\ Minutes) + (0.45)(30\ Minutes) + (0.7)(60\ Minutes)}{(0.3) + (0.45) + (0.7)}$$

= *Sprinkler turn on duration of 38.275 Minutes*

Fig. 7 illustrates the membership function of the Singleton output, presenting three distinct input values: "short," "medium," and "long." In this context, the fuzzy output labeled as "short" carries no time weight, indicating a sprinkler activation time of zero minutes; "medium" corresponds to a designated time of 30 minutes, whereas "long" is associated with a predefined duration of 60 minutes.

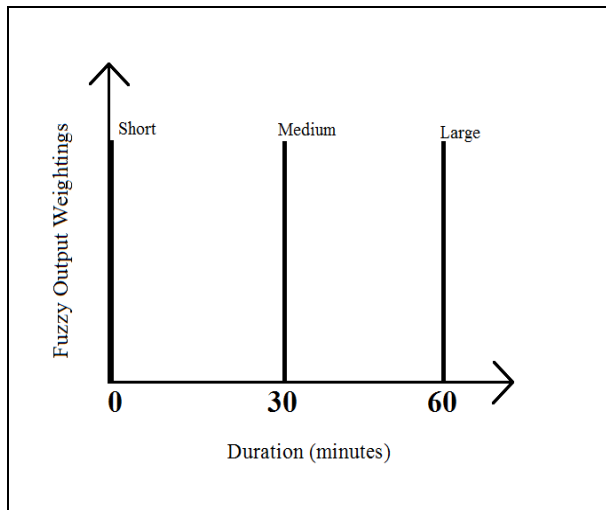

Fig. 7: Sprinkler turn-on duration

3 RESULTS AND DISCUSSION

3.1 System Overview

The agricultural plot necessitating watering is equipped with an array of detectors, including those tailored for gauging soil dampness, atmospheric humidity, thermal conditions, and rates of vaporization. The data amassed by these detectors is relayed to a Multiplexer, which functions to designate specific conduits for data manipulation. The Multiplexer's output is then linked to an Analog to Digital Converter (ADC), responsible for transforming the analog data into an electronic format. After being digitalized, the result is sent to the microcontroller, which relays it to a signaling device. The transmitter employs wireless communication to dispatch this data via an antenna. At the receiving end, near the remotely controlled station, there's an antenna which receives the transmitted data. This data is decoded and transmitted to a computer. A fuzzy control system implemented in MATLAB is employed to calculate control values for the sprinkler pipe valves. Moreover, a Visual Basic application is employed to oversee the variables that were entered and the resultant output data from the entire operation. This setup functions as a continuous feedback mechanism, persistently identifying parameters and relaying them until the farm achieves the targeted water level (set point).

3.2 Data Analysis

The data regarding the circumstances within the watering domain is acquired via the utilization of detectors. There exist four distinct detectors deployed to acquire real-time insights from the domain. These detectors are delineated as follows:

- Utilizing IC LM35 temperature sensors facilitates the conversion of real temperature values into appropriate power levels. This transformation enables the representation of temperature through an electrical impulse, thereby facilitating the measurement of atmospheric and soil temperature conditions. Two sensors are used, with one positioned above the soil and the other within the soil. ADC receives the resultant signal and sends the resultant voltage to the microcontroller's inputs line. There are two options for this type of sensor: LM34 and LM35, providing temperature readings in Fahrenheit and Celsius scales, respectively. Precise integrated circuit temperature sensors of the LM35 series generate a final signal that is precisely correlated to the temperature (in Celsius).
- The term "soil moisture" delineates the quantity of aqueous content within a defined spatial extent of soil, discernible through tactile and visual characteristics of the substrate. Electrical Resistance Sensors (ERS) are employed for this purpose, featuring two 5-inch probes made of Brass with Nickel electroplating. The sensing device is split into two portions, one of which is placed in the ground and the other resting on a wire pair. These sensors can continuously collect data with minimal maintenance using data loggers. In order to translate detected signals into volumetric quantity of water, ERS sensors (like the majority of soil moisture meters), need to be calibrated.
- The velocity of the air can be quantified utilizing an anemometer. This apparatus is fabricated by affixing bisected table tennis spheres to the apex of a revolving pole. The pole comprises a circular plate with uniformly distributed apertures, and two divisions of an Optocoupler (MOC7811) are situated on either flank of the plate. These divisions discern signals at every instance the illumination traverses through an aperture in the plate. The quantity of apertures in the plate dictates the frequency of air velocity updates; the temporal span between signal impulses can be utilized to compute the air velocity.

- A tube with an internal level sensor and water inside can be used to monitor the evaporation. The water level drops as the water in the tube evaporates, and when it reaches a certain point, a switch is activated, signalling the microcontroller. This signal informs the controller that there has been enough evaporation, causing the irrigation system to start up again.

3.3 Data Acquisition in Microcontroller

The microcontroller functions as a fusion of a microprocessor, memory, input/output interfaces, and additional components like timers, all condensed onto one chip. Serving as the central component, it governs our system's operations. It is responsible for picking the channel, collecting data, and using an RF module to send the data to a PC. A visual representation of the program's sequence is depicted in Fig. 8, elucidating the programming logic clearly.

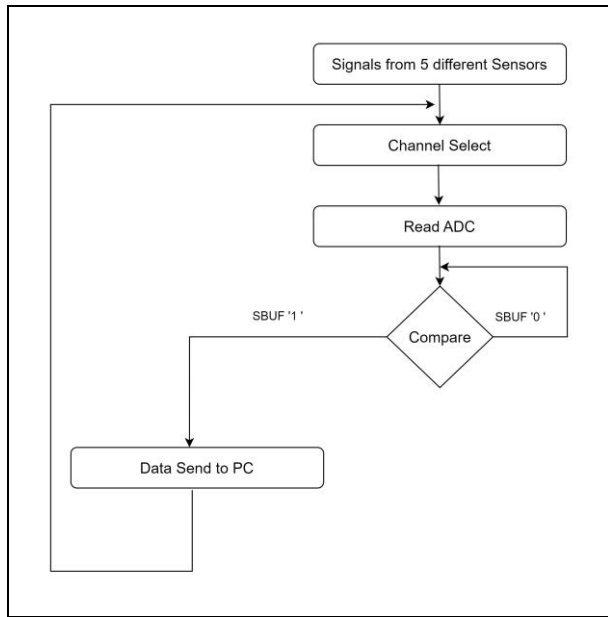

Fig. 8: Flowchart of encoding five sensors' input

3.4 Monitored using Visual Basic Program

Window-based programming involves the observation of five different factors, namely evaporation, soil temperature, air temperature, wind, and humidity. The program's sequential steps are illustrated in Fig. 9. Information is collected wirelessly from a microcontroller, transformed into fuzzy set data, compared against predefined threshold values, and overseen using Visual Basic. The results of this monitoring process are depicted in Fig. 10, showcasing the Visual Basic program's output. This output not only

observes the gathered data but also regulates results through a connection to a relay circuitry via a printer port.

Consequently, our manipulations are presented differently in Fig. 11. This involves a system that reacts to input information, imprecise data, and target data. Determining the irrigation requirements for the crop is accomplished through specific calculations and subsequent control actions. The hardware components are seamlessly integrated with the Visual Basic program through a communication port (COM port).

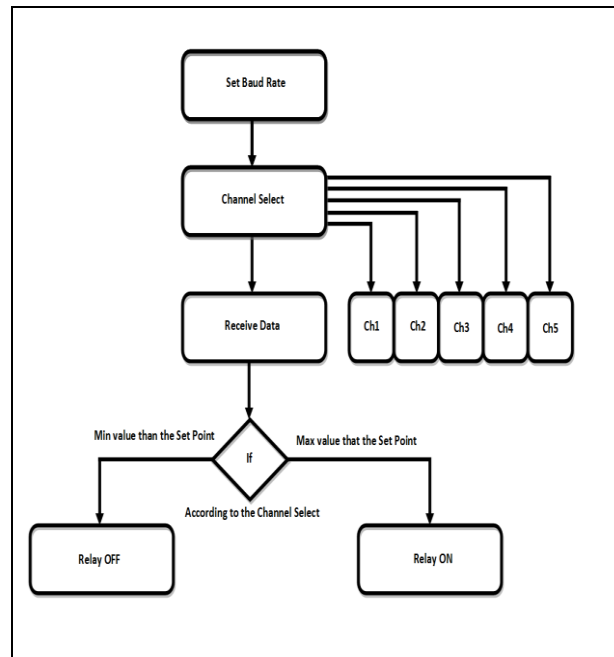

Fig. 9: Flowchart of input data comparison with set point

3.5 Sprinkler and Pump

Sprinkler irrigation closely mimics natural rainfall by dispersing water as droplets into the air. This method is widely embraced due to its user-friendly operation and is prevalent in various regions. It facilitates the even distribution of water. Crops are watered using a type of sprinkler that emits a spray. The core component of irrigation systems is a pump that is compatible with the specifications of the water supply, pipes system, and an irrigation equipment which is essential for improving the efficiency of an irrigation system. There are several types of pumps available for irrigation, including centrifugal, deep-well turbine, submersible, and propeller pumps. It is essential to retain that underwater. Generator, and propelling mechanism pumps are specific kinds of centrifugal pumps that operate differently. The choosing of the pump should harmonize with the motor specifications that suit the specific need.

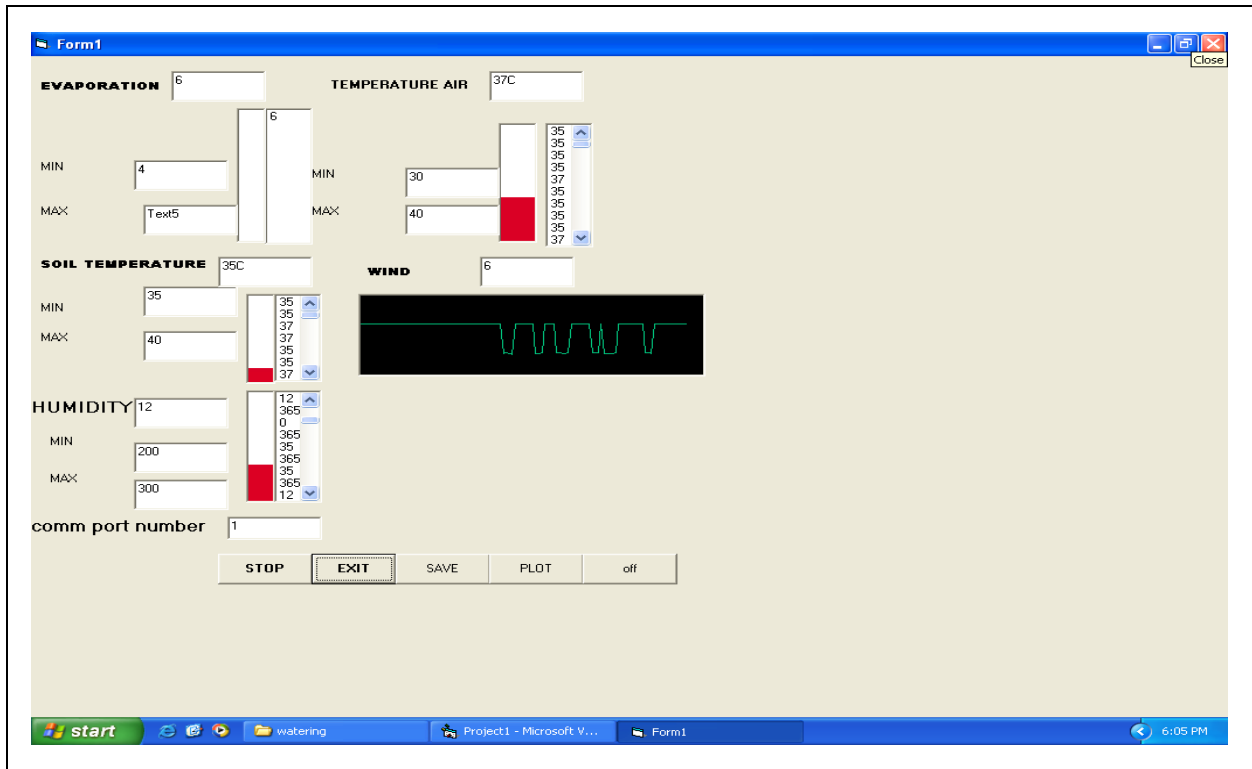

Fig. 10: Visual Basic program output

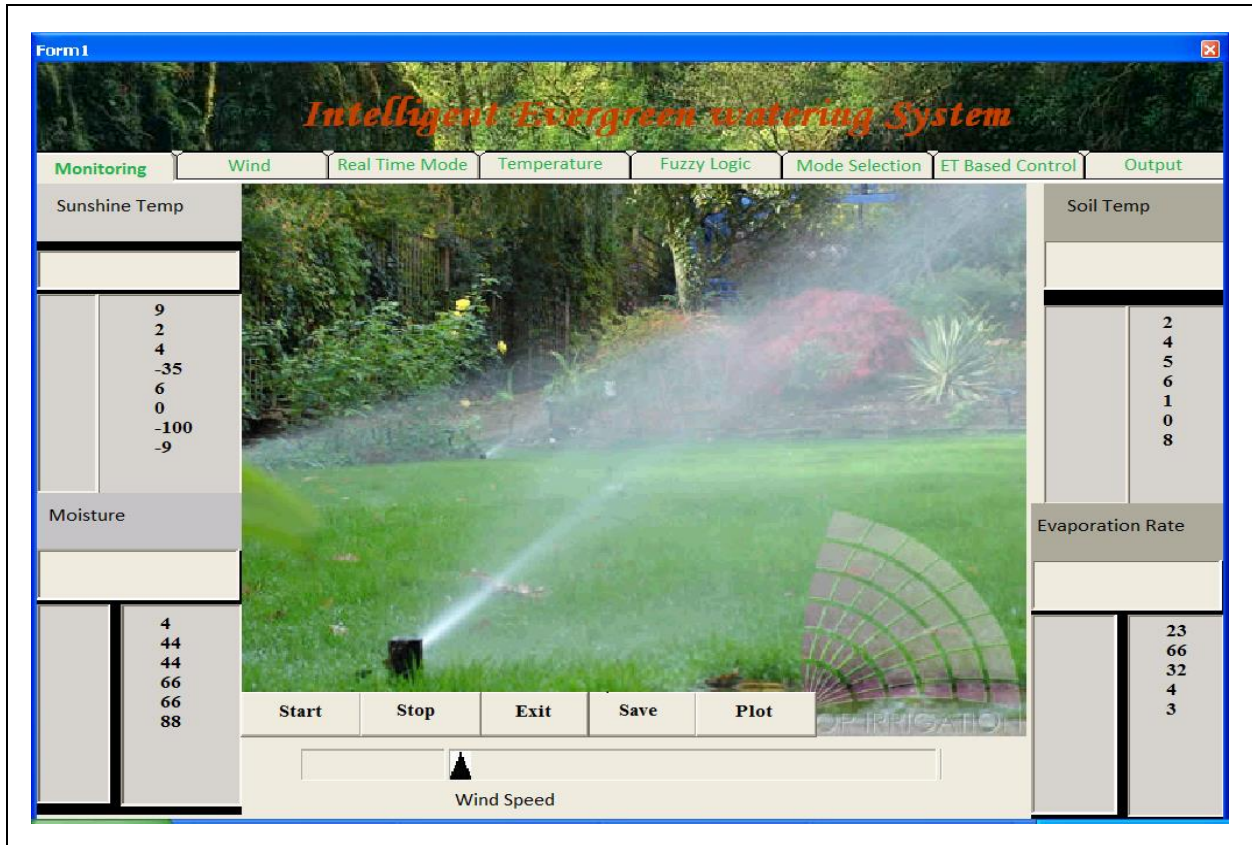

Fig. 11: Monitoring form in Visual Basic

4. CONCLUSION

In essence, solar radiation data-driven irrigation systems offer a comprehensive approach to address the challenges of water scarcity, energy consumption, and climate change in agriculture. By harnessing the power of solar energy and integrating it with irrigation practices, these systems pave the way for a more resilient, efficient, and environmentally responsible approach to crop cultivation. As technology continues to advance, the synergy between solar radiation data and irrigation systems will become even more refined, resulting in greater agricultural productivity and a more sustainable future. This paper has outlined the utilization of a Fuzzy-based controller, overseen by Visual Basic; the information was acquired through sensors, capturing specific metrics that are then conveyed, supervised, and managed from a distant location. The system functions effectively within an appropriate range, displaying stability. Its primary purpose is to efficiently conserve water at a low cost. The maintenance is straightforward, and it can be applied to irrigate various crop varieties effectively.

FUNDING

This research received no specific grant from any funding agency in the public, commercial, or not-for-profit sectors.

CONFLICTS OF INTEREST

The authors declare that there is no conflict of interest.

COPYRIGHT

This article is an open-access article distributed under the terms and conditions of the Creative Commons Attribution (CC BY) license (<http://creativecommons.org/licenses/by/4.0/>).



REFERENCES

- Ahmad, J. A., Forman, B. A. and Kumar, S. V., Soil moisture estimation in South Asia via assimilation of SMAP retrievals, *Hydrol. Earth Syst. Sci.*, 26(8), 2221-2243 (2022).
<https://doi.org/10.5194/hess-26-2221-2022>
- Al-Faraj, A., Meyer, G. E. and Horst, G. L., A crop water stress index for tall fescue (*Festuca arundinacea* Schreb.) irrigation decision-making—a fuzzy logic method, *Comput. Electron. Agric.*, 32(2), 69-84 (2001).
[https://doi.org/10.1016/S0168-1699\(01\)00161-2](https://doi.org/10.1016/S0168-1699(01)00161-2)
- Atsalakis, G. and Minoudaki, C., Daily irrigation water demand prediction using Adaptive Neuro-Fuzzy Inferences Systems (ANFIS). In *Proceedings of the 3rd IASME/WSEAS International Conference on energy, environment, ecosystems and sustainable development (EEESD'07)*, Agios Nikolaos, Crete Island, Greece, 24-26 July, 2007, 368-373(2007).
- Bwambale, E., Abagale, F. K. and Anornu, G. K., Smart irrigation monitoring and control strategies for improving water use efficiency in precision agriculture: A review, *Agric. Water Manage.*, 260, 107324, (2022).
<https://doi.org/10.1016/j.agwat.2021.107324>
- Joshi, A., Pradhan, B., Gite, S. and Chakraborty, S., Remote-Sensing Data and Deep-Learning Techniques in Crop Mapping and Yield Prediction: A Systematic Review, *Remote Sens.*, 15(8), 2014 (2023).
<https://doi.org/10.3390/rs15082014>
- Khong, A., Wang, J. K., Quiring, S. M. and Ford, T. W., Soil moisture variability in Iowa, *Int. J. Climatol.*, 35(10), 2837-2848 (2015).
<https://doi.org/10.1002/joc.4176>
- Mashala, M. J., Dube, T., Mudereri, B. T., Ayisi, K. K. and Ramudzuli, M. R., A Systematic Review on Advancements in Remote Sensing for Assessing and Monitoring Land Use and Land Cover Changes Impacts on Surface Water Resources in Semi-Arid Tropical Environments, *Remote Sens.*, 15(16), 3926 (2023).
<https://doi.org/10.3390/rs15163926>
- Pan, F. and Nieswiadomy, M., Estimating daily root-zone soil moisture in snow-dominated regions using an empirical soil moisture diagnostic equation, *J. Hydrol.*, 542, 938-952 (2016).
<https://doi.org/10.1016/j.jhydrol.2016.09.063>
- Pan, F., Nieswiadomy, M. and Qian, S., Application of a soil moisture diagnostic equation for estimating root-zone soil moisture in arid and semi-arid regions, *J. Hydrol.*, 524, 296-310 (2015).
<https://doi.org/10.1016/j.jhydrol.2015.02.044>
- Ridolfi, L., D'Odorico, P., Porporato, A. and Rodriguez-Iturbe, I., Stochastic soil moisture dynamics along a hillslope, *J. Hydrol.*, 272(1-4), 264-275 (2003).
[https://doi.org/10.1016/S0022-1694\(02\)00270-6](https://doi.org/10.1016/S0022-1694(02)00270-6)
- Roberts, J. B., Robertson, F. R., Clayson, C. A. and Bosilovich, M. G., Characterization of Turbulent Latent and Sensible Heat Flux Exchange between the Atmosphere and Ocean in MERRA, *J. Clim.*, 25(3), 821-838 (2012).
<https://doi.org/10.1175/jcli-d-11-00029.1>
- Scowen, M., Athanasiadis, I. N., Bullock, J. M., Eigenbrod, F. and Willcock, S., The current and future uses of machine learning in ecosystem service research. *Science of the Total Environment*, 799, 149263 (2021).
<https://doi.org/10.1016/j.scitotenv.2021.149263>
- Settin, T., Botter, G., Rodriguez-Iturbe, I. and Rinaldo, A., Numerical studies on soil moisture distributions in heterogeneous catchments, *Water Resour. Res.*, 43(5), W05425 (2007).
<https://doi.org/10.1029/2006wr005737>
- Zhu, Q. and Lin, H., Influences of soil, terrain, and crop growth on soil moisture variation from transect to farm scales, *Geoderma*, 163(1-2), 45-54 (2011).
<https://doi.org/10.1016/j.geoderma.2011.03.015>